

Critical Power for Broadcasting Applications



Selecting the Right Power Protection System

The broadcast industry is well into the digital revolution with most facilities heavily reliant on power sensitive computer based equipment. This makes power protection systems a critical necessity. Recently many customers in the broadcasting industry have come across unique requirements for their power protection applications. This is due to the advent of devices such as IOT type transmitters that have power requirements like high surge currents or "crowbars". In addition, the prevalence of sensitive electronics now demands tightly regulated voltage levels under all operating conditions making the requirements for broadcasting power protection different from that of other applications.

Specific Requirements of UPSs in Broadcasting Applications

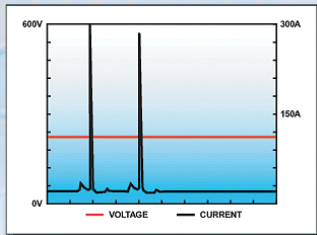

Profile of transmitter current during the crowbar effect

The UPSs ability to handle the crowbar effect
Many broadcast transmitters use IOT type transmitter tubes. To protect the tube against adverse operating conditions that may damage these very expensive investments they have the ability to short to ground for a very brief period (10-50 mS) in what is known as the "crowbar effect".

This effectively shunts the power across the tube and protects it from out of tolerance operating conditions. During a crowbar event (a virtual dead short when the high voltage source is shorted to ground), the source current surges to many times that of the transmitters nominal rating.

When a UPS (Uninterruptible Power Supply) is protecting an IOT transmitter during a crowbar event, the UPS must be capable of managing the dead short without damage to itself or experiencing an interruption in operation. Under normal operating conditions the UPS is supplying power via the inverter. Once the output current exceeds the inverter's overload capacity the UPS will instantly transfer to the bypass source by closing the static transfer switch (a fast acting solid state power switch). In most cases the bypass current is supplied by utility power, which has plenty of fault clearing capacity to ride through the crowbar. As soon as the current subsides to within the inverter's tolerance, the UPS returns to inverter power. The whole transfer from the inverter to the bypass source and back is a virtually seamless overlap transfer with no breaks visible to the load.

If you are determined never to let the transmitter see utility power, even when experiencing a crowbar event, you can oversize the UPS so that its inverter will have enough capacity to ride through such overloads. Most UPS inverters will be able to sustain 150% of the nominal current for the duration of the overload 1-5 cycles. Unfortunately this solution is extremely costly considering that it may double or triple the cost of your UPS investment.

Not every UPS is suitable for managing crowbar events (dead shorts on the output). While the simple solution is to oversize the UPS so that it maintains inverter power during a dead short, this may be extremely expensive and impractical. In addition, it is difficult to determine how much current will be dissipated during a short (this will vary depending on where in the cycle the short occurs). For these reasons it is essential that a UPS selected to operate with IOT transmitters be capable of experiencing a dead short on the output without shutting down or damaging internal components. If it is deemed critical that the UPS stay on inverter power (on-line) even during a crowbar, most UPSs will sustain a 150% overload while staying on-line. Thus, over sizing the UPS by a factor of three will provide for overloads roughly five times that of the UPSs' nominal rated output current.

MGE's EPS 6000 UPSs have been the UPS of choice for broadcasting and IOT transmitter applications primarily because they have the ability to sustain dead shorts on the output without damage to the UPS and continue to operate seamlessly throughout the entire crowbar cycle. This is due to the MGE's Digital Power Quality management technology that generates the output sine wave from hundreds of small pulses (pulse width modulation). In the event that the sensing circuitry detects that the output current exceeds 167% of the nominal current, the inverter instantly stops in micro sub cycle resolution protecting the power transistors from over current. Simultaneously it closes the bypass static switch allowing utility power to clear the output fault. Other inverters with slower dynamic response may have to ride through an entire cycle before shutting down on an overload, burdening the power semiconductors (IGBTs or Insulated Gate Bipolar Transistors) beyond their thermal capacities and permanently damaging the UPS.

Since the static switches on MGE's EPS 6000/8000s are 100% continuous duty rated and do not rely on overlap mechanical contactors to assist with the capacity, they sustain up to 22 times the nominal rated current of the UPS, clearing even the worst fault. Once the overload subsides, the invert restarts supplying protected power to the load again. The management of

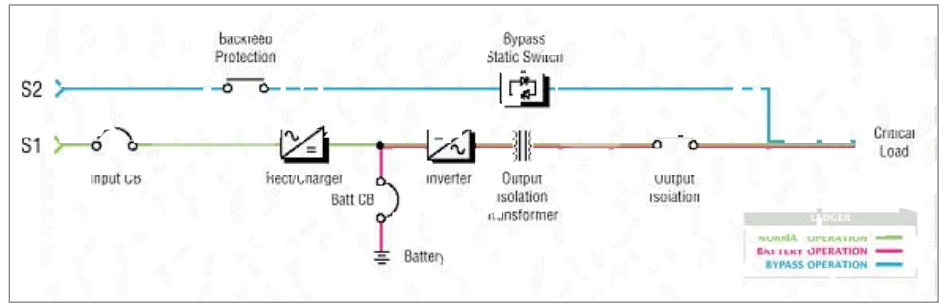

UPS Operation ~ Under normal operation the UPS is feeding power to the load from the inverter. Once it is detected that the load exceeds 167% for any instant, the inverter is stopped in sub-cycle resolution to prevent damage to its components. Simultaneously, the Bypass Static Switch is closed allowing utility power to assume the load and clear the fault current. Since the inverter is always synchronized to utility power the whole transfer is seamless and does not affect power quality. Since the Bypass Static Switch is rated to sustain up to 22 times the nominal load, it can sustain faults such as crowbars without damage to the UPS. Once the fault is cleared, the UPS seamlessly returns to normal operation.

the short circuit condition is a seamless overlap transfer to utility power and back to inverter.

In addition to selecting a UPS that can handle the fault current, considerations should also be given to ensure adequate circuit breaker trip co-ordination at the input of the UPS and bypass source. If not properly sized the feeder breakers may trip on a crowbar despite the fact that the UPS could sustain the current.

Transmitter applications also have to consider the start up surge current of the High Voltage Power Supply. (HVPS). In the illustration of an actual system in Figure 4, the current surges to 200 A or up to four times the nominal power for a few cycles before stabilizing. Typically the UPS should be sized so that it can stay on inverter power and maintain output voltage regulation during this surge condition. Since the EPS 6000 maintains tight voltage regulation even during 0-100% block loads or "step loads" like HVPS start ups, the line voltage quality will not be compromised.

Since broadcast facilities contain very sensitive equipment it is vital that the UPS maintain a stable and tightly regulated voltage. If the inverter output of the UPS sags during rapid changes in the current demand such as HVPS start ups, it may drop other electronic loads sharing the UPS output. Also if the UPS inverter is not able to tightly regulate the voltage during these "step loads", such as an HVPS startup, then the voltage may also surge or sag out of tolerance during these surge conditions. A further advantage of the EPS 6000 is that it maintains tight regulation up to 150% overload when on inverter power.

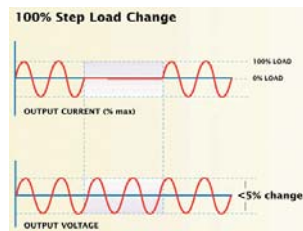

Step loads such as an instant jump from 0% load to 100% load should not result in a major change in UPS voltage (ideally less than 5% change on any given phase).

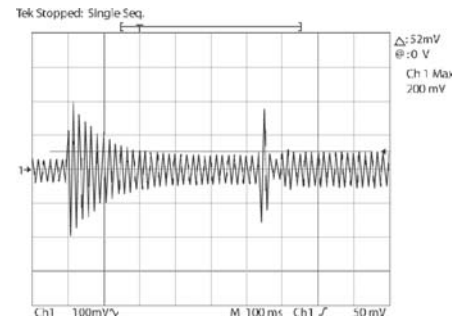

Current demand during HVPS starting

UPS Generator Compatibility

Since most large broadcast applications pair the UPS with a generator system, it is important to understand the issues influencing UPS generator compatibility. The main problem with UPS/generators compatibility is that UPSs can become highly leading power factor loads when loaded below 30-40% of their capacity. The reason is due to the capacitors used in the input filter of the UPS (required on large UPSs to reduce the harmonic distortion reflected by the rectifier onto the utility line). The reactive current from the capacitors reflect back onto the generator bus. If the reactive current /kVARs (leading power factor) is high enough, it will cause the generator to lose voltage regulation.

The traditional approach to solving the problem was to oversize the generator by a factor of three times that of the UPS rating. Since a generator can take a finite amount of VARs (reactive current) proportional to rating, an oversized generator can accommodate the extreme amount of reactive current reflected by a UPS at light loads.

To alleviate this problem of over sizing, some manufacturers attempted to disengage the capacitors on the filters at light loads using a mechanical contactor.

The result was an extreme notch into utility voltage each time the capacitors were switched, along with a huge jump in the distortion reflected onto the utility.

MGE has taken a new approach to assuring UPS/generator compatibility. By using inductors to mitigate harmonics in place of capacitors, the capacitance values (the cause of the leading power factor / kVARs) can be lowered on the RC circuit of the input filter. The result is a "low kVAR" filter where the reactive current reflected by the UPS input onto the generator bus is well within the acceptable limits of the generator (reactive current / VARs are limited to less than 15% of the nominal input current—a safe ration for most generators).

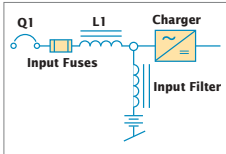

MGE's low kVAR filter uses high inductance and low capacitance to limit the leading power factor generated by the input filter.

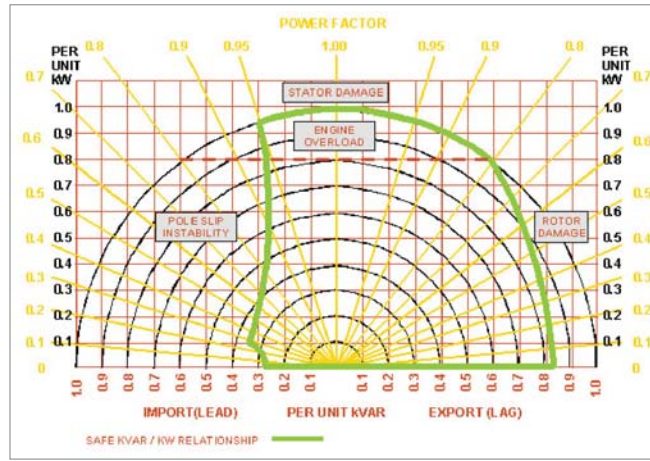

Any given generator set can only accommodate a finite volume of reactive power (kVARs) reflected from leading power factor loads. The graph above shows the permissible limits of kW / KVAR (inside the green line) for a typical generator.

This MGE solution
not only ensures compatibility and takes the risk out of the equation but also reduces the expense associated with generator oversizing.

The Proving Ground ~ Factory Testing UPS Systems

To ensure that you select a UPS that will protect your application under all conditions, it is strongly suggested that you perform simulation tests at the manufacturer's facility. This is the only way to ensure that the UPS will perform without compromise under your specific conditions. The two most essential "witness tests" are, a) step loading and b) bolted short tests.

Step loading demonstrates the UPS's ability to maintain a tightly regulated voltage on all three phases when the output load dramatically changes. Such changes are experienced



when HVPS starts up or when heavy lighting loads, distribution transformers, motors and even banks of IT load start up. A true measure of a UPS's step load performance is taking the output from 0% to 100% load instantaneously or in the case of broadcast applications even 0-150% load, and then back down to 0% load. During this time the output voltage is observed and should not deviate by more than a couple of percent on any give phase.



The second test is a bolted short in which two phases of the UPS output are shorted into each other. In many cases a crowbar is equivalent to a bolted short and it is critical that the UPS survive and clear the fault during the short circuit condition. Many UPSs are very fickle and may experience catastrophic component failures

during these all too common short circuit conditions that can occur not just with transmitters but as a result of downstream equipment failure or even miswiring (keep in mind it takes around 6 cycles for a breaker to trip, during which time the UPS must support the short).

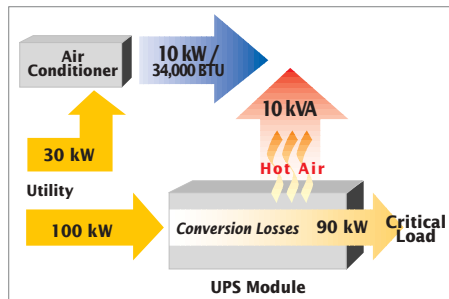

Efficiency can be measured as the percentage of power that goes into the UPS versus the power available at the output. A high efficiency UPS will result in substantial energy costs savings

Another important factor to evaluate in real life test conditions is UPS efficiency—simply defined as what percent of energy goes into the UPS that comes out as usable power. Most UPSs will be over 90% efficient, but doing the math, even an efficiency advantage as small as 2% between one UPS over another can translate to energy savings equal to the cost of the UPS in as little as three to five years!!! This makes UPS efficiency a big deal especially in the case of large UPSs when efficiency advantages translate to huge cost savings. Again, efficiency should not be compared on manufacturers brochures, but rather under real life conditions in a test bay. This is largely because efficiencies are typically much higher when UPSs are operating fully loaded and when they are powering linear loads. In real life operating conditions most UPSs are operating well under 50% load and nearly always powering non-linear loads. MGE's EPS 6000 UPS offers industry leading

efficiency under real life conditions making it the least expensive choice while offering the best performance characteristics.

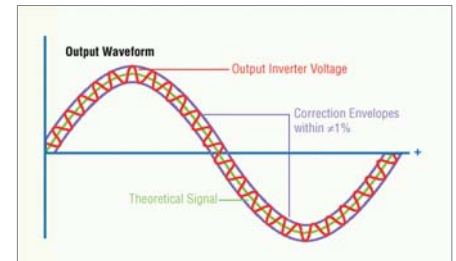

- MGE's Digital Power Quality algorithm constantly samples the waveform voltage and makes sub cycle corrections to maintain a tight power quality window.

Testing the quality of the output voltage from the UPS is also strongly recommended. The broadcast industry is extremely sensitive to interference (noise and distortion) that can disturb signal quality. Noise can exist in the form of harmonic distortion reflected on the UPS output, or can be conducted as ripple on top of the AC waveform. MGE restricts output THD to around 3.5% even on non-linear loads. Effectively the UPS is also operating as an active filter, eliminating many common sources of noise that can disturb audio and video equipment. This low distortion is achieved by using MGE's unique Digital Power Quality algorithm that creates the output waveform from hundred of sub cycle micro pulses. Hundreds of times a second the waveform is compared to a theoretical perfect sine wave with sub cycle adjustments made to the next pulse to ensure the output voltage conforms to tight power quality window.

The Proven Solution



MGE EPS 6000 UPS supporting an IOT transmitter. This site has experienced numerous crowbars with the UPSs managing the fault without incident.

MGE UPS SYSTEMS

provides power protection to many of the nation's broadcasters. These pictures show an EPS 6000 protecting an IOT type transmitter. This site was commissioned and placed in service in March of 1999 and has been operating without incident. The load consists of a television transmitter manufactured by Harris, Sigma Plus series, with two IOT's (Inductive Output Tubes). The nominal load on the UPS was 54% / kW.

This facility was visited to witness the effects on the UPS while simulating a "Crowbar". Each of the two IOT's was forced into a "Crowbar". The UPS managed the crowbar without incident. In this case the output current was three to five times the nominal UPS output current. To effectively manage the current, the UPS seamlessly transferred to bypass (utility) allowing the utility current to effectively clear the fault. The UPS then re-transferred back on-line (to inverter power) automatically without incident immediately after the dead short was cleared. In summary, the EPS6000 performed flawlessly as expected.

MGE UPS SYSTEMS

USA (headquarters)
1660 Scenic Avenue
Costa Mesa, CA 92626
tel (800) 523-0142
(714) 557-1636
fax (714) 557-9788

CANADA
#9, 2798 Thamesgate Dr.
Mississauga, ON L4T 4E8
tel (905) 672-0990
(877) 672-0990
fax (905) 672-7667

ARGENTINA
Thames 91
1609 San Isidro
Prov de Buenos Aires
tel (54) 11-4766-8777
fax (54) 11-4766-6008

BRAZIL
Avenida Guido
Caloi 1985 (GALPAO 23)
Guarapiranga
Sao Paulo - SP, CEP 05802
tel (55) 11-5515-9255
fax (55) 11-5515-9250

MEXICO
Ave. Congreso de la
Union
#524 Colonia Santa Anita
Mexico D.F 08300
tel 525 538 9687
fax 525 530 7625

www.mgeups.com
info@mgeups.com
Bdrctst 100
Effective: July 2003