

MGE™ EPS™ 7000

Three phase UPS

300/400/500 kVA



Performance 3phase Power Protection with high adaptability to meet the unique requirements of medium to large datacenters, buildings and mission critical environment.

- > Flexible and very adaptable
- > Strong electrical features
- > Intuitive monitoring
- > Parallel capable output
- > Synchronization to external source
- > High availability architecture components

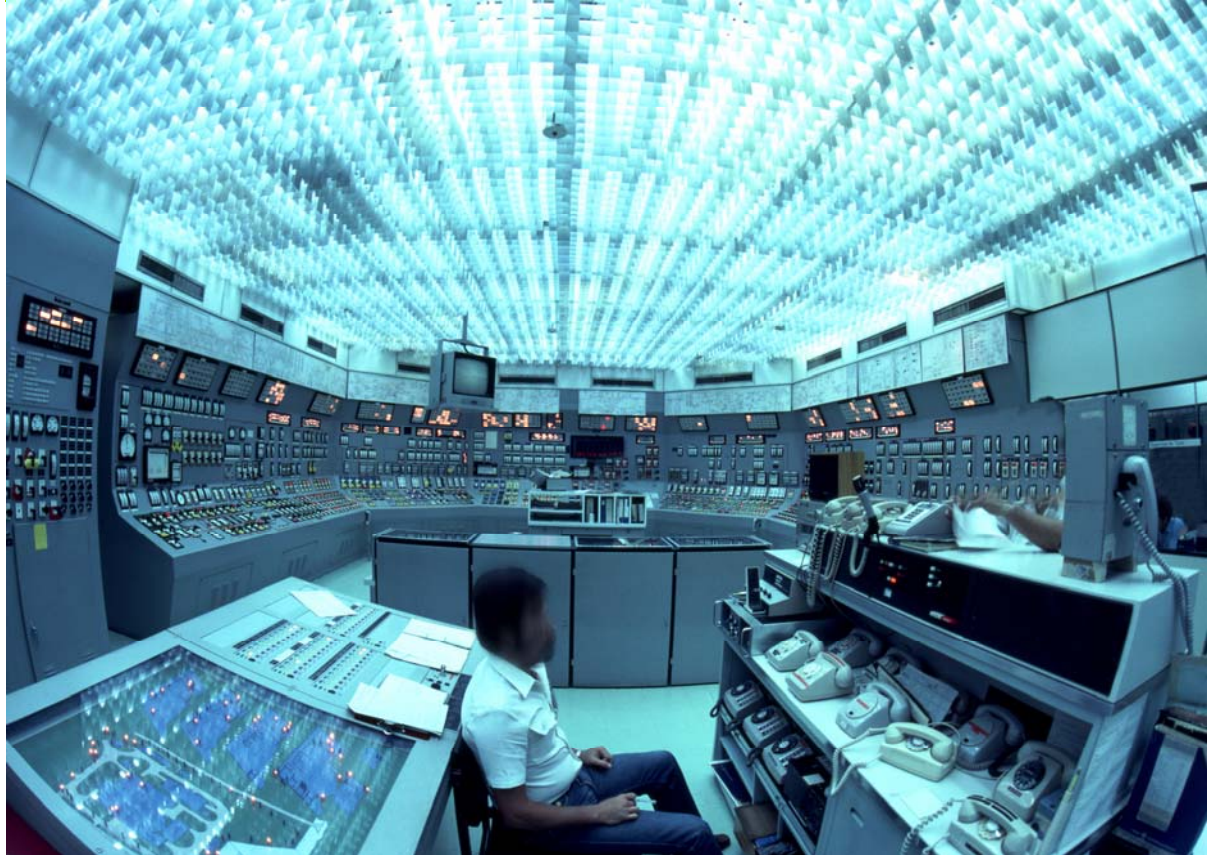

 + APC
MGE = peace of mind

Customer

MGE™ EPS™ 7000 Features

Digital Power Quality Inverter

The most outstanding feature of the MGE™ EPST™ 8000 is the digital inverter. Using a unique technology called Digital Power Quality Management (DPQM), the inverter maintains precision voltage regulation under all operating conditions. The key to the superior performance lies in the speed and resolution of the waveform which is generated by up to eight pulses per millisecond allowing the waveform to be tightly controlled. The waveform is constantly compared to a real time reference sine wave. If the sine wave deviates from the reference sine wave, the gain of the inverter output is adjusted creating a "correction" pulse maintaining a "power quality envelope" that is $\pm 1\%$ of a perfect sine wave. A free switching frequency accelerates during periods of major variations for better regulation. By optimizing the switching frequency, the MGE™ EPST™ 8000 is also able to minimize switching losses and maintain a high efficiency level even at lower loads.

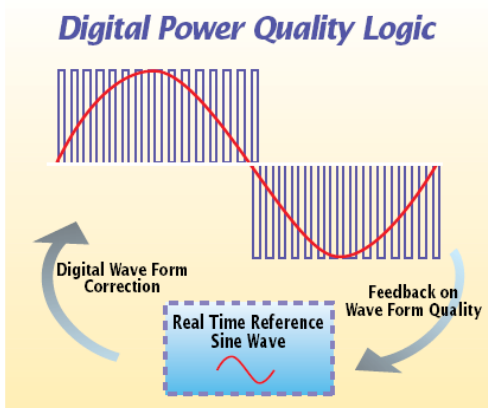

Another benefit of the high-resolution control topology is that harmonic distortion reflected from the loads is practically eliminated. The error correction pulses counteract the reflected waveform distortion reducing THD to under 4%.

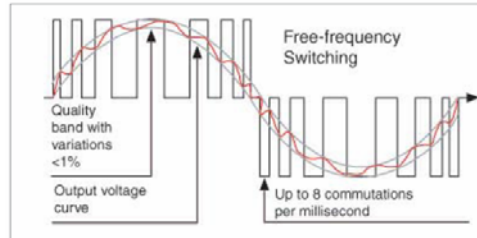

Some other UPS manufacturers claim they have PWM inverters but have simply continued to use their old SCR based inverter designs and substituted IGBT's (Insulated Gate Bipolar Transistors) into the circuit where the SCR once was used. Since these designs still switch the transistors at 60 Hz (very slow) they effectively produce a step wave and have no active sub cycle filtering capability to combat reflected harmonics and can not respond quickly to dynamic (i.e step) loads. To convert the step wave output to a sine wave the inverter output needs to be put through extensive filtering system before it can appear as a sine wave. Even after filtering, this technology still leave remnants of a step wave visible on a scope trace. The dependency on the inverter trap filtering also reduces reliability, as it is another failure risk added to the circuit.

UPS Input Filter Technology

The technology used to maintains the input power factor and avoid leading PF loads is an important consideration.

Many other large UPS rely on disengaging the input filter capacitors with a contactor at lower loads where the UPS risks becoming a leading PF load. Switching capacitors will create large notches and disturbances on the utility bus. Furthermore the system is relying on a mechanical contactor.

APC's system is based strictly on a solid state inductor assembly balancing the effect of the capacitors – a safe and reliable technology.

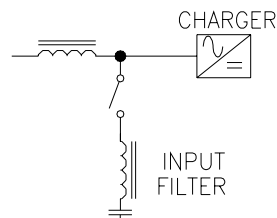

MGE™ EPS™ 7000 Features

Solid State Disc SCR Transfer Switch

APC by Schneider uses large hockey puck SCRs in its static bypass.

The ability to clear faults safely is dictated by the capacity of the static bypass switch.

Because these SCRs can tolerate quick fault currents over 22 times that of the UPS rating.

They can safely use the fault clearing power of the utility to clear the fault without any damage to the UPS.

Many other UPSs typically use lower current brick type SCRs on their static switches that are only momentary rated and rely on an overlap contactor to carry the current. Because fault current rises so quickly, it can often exceed the rating of these momentary SCRs before the contactor has a chance to engage.

The fault clearing capability of the UPS is regulated by capacity of the static bypass switch.

MGE™ EPS™ 7000 uses robust disc SCR static bypass switch which is able to clear instantaneous faults current over 20 times the UPS's nominal rating

MGE™ EPS™ 7000 bypass is 100% continuous duty rated making it more reliable than systems that pair smaller, momentary rated SCRs with an overlapped contactor.

Demonstrated Reliability as the Industry's Best UPS

Reliability can be expressed on paper with mathematical equations and even via standards such as MIL-217. Mathematical methods of expressing reliability are subject to the methodology, with even well recognized standards with defined methodologies differing from calculation to calculation and subject to creative interpretation. In fact, when comparing most major manufacturers reliability according to MIL-217, the results are very close. MGE prefers to measure the reliability of the MGE™ EPST™ 7000 by looking at our customers and more importantly the number of customers who continue to buy our systems. MGE™ EPST™ 7000 customers include the world's largest Internet providers, semi-conductor manufacturers, insurance and financial institutions and telecommunications companies. Many of these customers have the potential to lose more on single outage than the cost of the UPS making reliability the primary factor in selecting a UPS. Even after exhaustive independent consultant engineer investigations among all major UPS manufacturers, the MGE™ EPST™ 7000 has time and again proven to be the most reliable solution on the market. Furthermore, MGE has now supplied many of these same customers for the third time with the MGE™ EPST™ 7000 family.

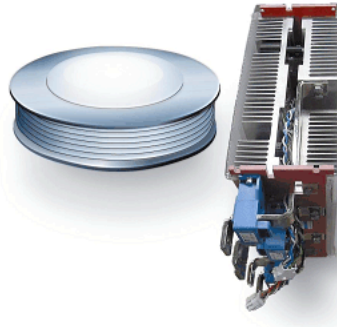

Fault Tolerant

Output faults are common events on any UPS system. Even a small downstream device fault may take four or five cycles before a distribution circuit breaker opens. This means that the UPS module must be capable of clearing the fault.

The reality is that no UPS manufacturer's inverter has the capacity to clear very large faults. IGBTs (the transistors) used in the inverters simply are not designed to sustain faults.

The key to managing faults is to firstly protect the inverter by current limiting it from fault conditions – and then safely make a seamless transfer to utility via the static bypass switch. The utility will have enough fault clearing capacity to clear any fault. Since the inverter is properly protected once the fault is cleared (either by opening the breaker or if it clears itself) – it can safely assume the critical again. MGE's fast current limiting avoids overloading the inverter – while the robust static bypass switch feeds enough utility power to clear the fault. The result is that the load will stay protected and the UPS will remain in tact.

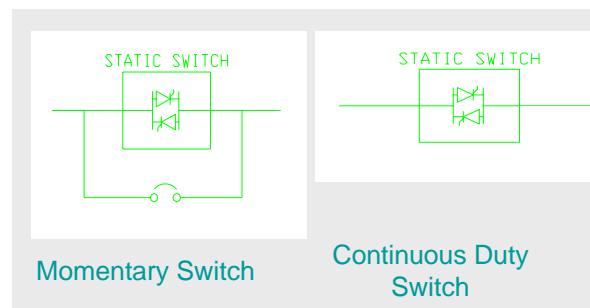

Specific Technical Advantage

Generator Compatibility/Input Filter Technology

The MGE™ EPST™ 7000 is the most generator friendly UPS thanks to its unique input filter technology. This technology eliminates one of the major reliability risks associated with large UPS systems- the failure of the generator to support the UPS under low load conditions. The 1 to 1 sizing ratio of the MGE™ EPST™ 7000 allows for significant cost saving by eliminating the need for generator over sizing.

Generator/UPS interaction problems are typically caused from the capacitors located in the input filter (used to regulate the THD reflected by the UPS rectifier) which create very high reactive currents at loads below 40% (where most UPSs operate). Most generators are not able to tolerate these reactive currents (high leading power factors) as they disturb the generator's voltage regulation circuit causing the generator to lose regulation and potentially go off-line.

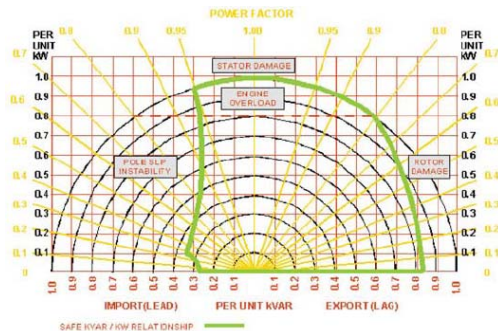

The traditional way to combat the problem of the UPSs reactive currents is to grossly oversize the generator by up to three times in the case of multi-module systems. This is an extremely expensive solution that also requires that the generator operate at very low loads—causing carbon build up and shortening the life of the generator. MGE's shunt inductor input filter technology provides a superior solution that both limits input THD and ensures that the input power factor never goes leading – at all load levels. This is achieved by using a passive shunt inductor to balance the power factor. The technology uses highly reliable passive components and does not involve any mechanical switching. The result is a very reliable filter technology that permits safe UPS/generator operation without excessive generator over sizing.

Battery Management

Batteries represent a significant investment in any UPS system – often half the cost. They are also have the highest risk of failure of any component. The MGE™ EPST™ 7000's battery management system performs two critical functions:

First it collects all the relevant inputs to display the most accurate time remaining.

Secondly by incorporating key details such as battery temperature, the MGE™ EPST™ 6000's rectifier continually optimizes the charge voltage to maximize battery life.

Full Output Voltage Regulation Over Entire Range of the Battery

The MGE™ EPST™ 7000 uses a 480 V DC bus. As a result of the DC bus closely matching the AC output voltage the MGE™ EPST™ 7000 is able to maintain the output voltage regulation over the whole operating range of the battery.

Some UPSs that use lower DC busses (using fewer batteries in series) may experience decaying output voltage as the battery voltage / DC bus drops during discharge.

This means that the MGE™ EPST™ 7000 UPS will be able to maintain perfect voltage regulation over the full range of the battery.

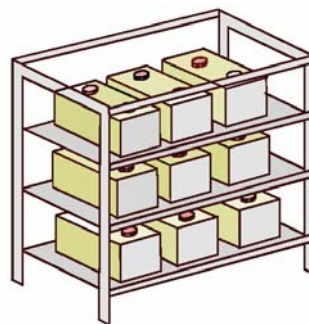

MGE™ EPS™ 7000 Options

Integrated Input Isolation Transformer

Every MGE™ EPS™ 7000 is equipped with an input isolation transformer fully integrated into the core module. Integrating the transformer directly into the module saves footprint and provides all the benefits of galvanic isolation including providing a very robust buffer between the utility and the critical load.

Graphical User Interface: (Optional)

The Advanced Graphical Interface for the MGE™ EPS™ 7000 UPS system features a 12" high contrast TFT LCD touch screen. Delivering features including animated mimic diagrams, alarm event logs, trending, component level status and more, the interface presents UPS status information in an easy to read graphical format. Guided by a clear menu, users can navigate through all screens to explore system level information on multi-module systems drilling right down to module and component level information. Operator procedures simplify the use of the UPS, contributing to an overall increase in reliability by mitigating user errors.

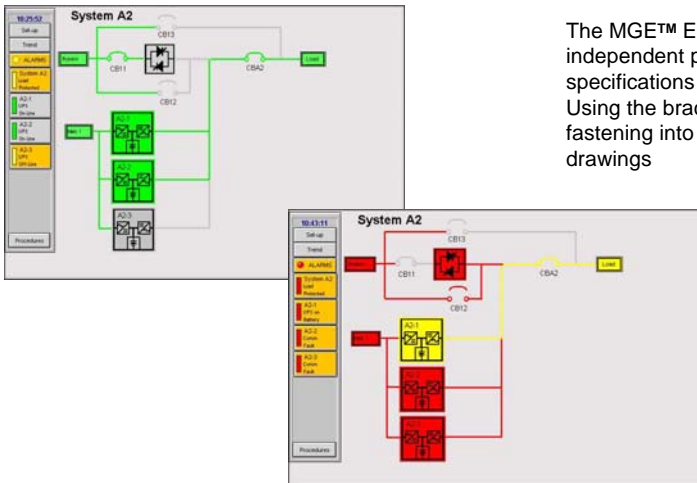

Options

- > Input Isolation Transformer
- > Output Distribution
- > External Maintenance Bypass
- > Bottom Cable Entry
- > Remote Alarm Status Panel
- > Seismic Anchors
- > SNMP/Network Management Card
- > Graphical User Interface with Network Connection
- > Battery Monitoring
- > Continuous Duty and Momentary Duty Static Switch Cabinets (SSC)
- > Critical Bus Synchronization Module
- > Battery Disconnect



Seismic Certification

The MGE™ EPS™ 7000 has been certified by independent professional engineers to Seismic ZONE 4 specifications .

Using the brackets supplied by APC by Schneider and fastening into the substrate as noted in the installation drawings

The most comprehensive range of services

Commissioning

Schneider Electric Critical Power and Cooling Services provides commissioning service for all new equipment with support to meet your specific requirements.

Managing an installation calls for Upgradeability

To be sure of benefiting from the management of an installation, Schneider Electric Critical Power and Cooling Services provides solutions for upgrading:

- technical upgrading
- upgrading battery functions
- site audits, studies and analysis of the UPS environment
- harmonic audits
- upgrading the UPS function using Swap-Pac for adapting and anticipating changes in customers' requirements as well as providing environmental end of life cycle management.



Maintenance contracts

A maintenance contract on your UPS ensures a smooth running system allowing you to focus on your core business. A maintenance partnership with the company that manufactures and installs your UPS systems provides continuity and service levels no one else can meet. APC by Schneider is pleased to offer the industry's most comprehensive, efficient and cost effective maintenance programs designed in an à la carte fashion to tailor the program to your specific needs.

While you can custom build a maintenance program specific to your site, APC has devised 3 basic packages that cover a majority of the needs of our customers. However, even these three packages can be customized to your precise specifications and budget. For example, additional services such as preventative maintenance visits, site inspections and remote monitoring can be added to each package so you get precisely the level of service you need.

• ULTRA :

APC by Schneider's most complete service package, Ultimate Agreements offer 7 x 24 back-up featuring 30 minute call back time on all service requests and on site arrival within four hours of your call (not available in all areas). All parts, replacement spare parts, labor, and travel expenses associated with the call are included with Ultimate Agreements.

• PREMIER :

For a superior level of coverage, Premier Service is available Monday through Friday, from 8:00AM - 5:00PM, local time, perfect for most businesses. This program guarantees a maximum 30-minute callback time, with on-site arrival of your APC by Schneider engineer on the next business day or sooner. All parts, replacement spare parts, labor, and travel expenses associated with visiting your site are included in this complete package.

• SELECT :

For a moderate level of coverage, Select Service offers a discount on parts and labor associated with corrective maintenance, 30-minutes maximum callback time, and next business day or sooner on-site arrival time. Parts, labor and travel expenses associated with corrective maintenance are billed separately at discounted time and material rates.

Technical characteristics

Rated power (kVA / kW)	300/270	400/360	500/450	300/270	400/360	500/450
Normal AC Input						
Input Voltage (V)	480 (+/- 10% , 3ph 3 Wire + Ground)			600(+/- 10% , 3ph 3 Wire + Ground)		
Frequency (Hz)	60 Hz +5%					
Power Factor	0.90 lagging with filter					
THDI	7% THDI at Full Load					
Nominal Input Current (A)	371	508	656	322	441	569
Maximum Input Current (A)	543	688	840	466	586	711
Nominal Bypass Current (A)	361	481	601	289	385	481
Input CB: Frame Size (A)	1000					
Input CB : Trip (A)	1200					
Bypass AC input						
Voltage (V)	Must Match Rectifier Input , +/- 10% UPS Output Voltage (3ph ,3/4 wire + ground)					
Frequency (Hz)	60 Hz (+/- 0.25 Hz up to 2.0 Hz)					
Maintenance Bypass CB Frame size (A)	800			700		
Maintenance Bypass CB Trip (A)	1200					
Output						
Output Voltage (V)	480(+/- 3% , 3ph 3 or 4 Wire + Ground)			600 (+/- 3% , 3ph 3 or 4 Wire + Ground)		
Power Factor	0.9 at nominal kVA / up to unity at rated nominal kW					
Frequency	60 Hz +0.1% free running synchronized with bypass					
Voltage Regulation	+/- 0.5% steady state					
Voltage Recovery time	+/- 1% of the steady state value within 1 cycle					
Voltage Distortion	2% L-L (4% L-N) THDI max.					
UPS Output Current (A)	361	481	601	289	385	481
Battery						
DC Current (Max)	721	962	1195	721	962	1195
DC Breaker Trip Size (A)	700	1000	1200	700	1000	1200
DC Breaker Frame Size (A)	1200					
Overall Efficiency						
System efficiency	94%		93%	94%		93%
Full Load Heat rejection (BTUs)	59400	78100	110750	65000	86000	112000
Environmental Conditions						
Acoustical noise level	75° dBA at 5 feet					
Operating temperature	0°C to 40°C (32°F to 104°F)					
Non-operating	-20°C to +45°C (-4°F to 113°F)					
Relative humidity	0 to 90% (non-condensing)					
Dimensions and Weights						
UPS Module (lbs)	6,900					
UPS Module (W x H x D)	69" x 82" x 39"					
Maintenance Bypass Cabinet (lbs)	540					
Maintenance Bypass Cabinet (W x H x D)	22.75" x 82" x 39"					
Bottom Entry Cabinet (lbs)	190					
Bottom Entry Cabinet (W x H x D)	14" x 82" x 39"					
Transformer Cabinet (lbs)	3,600					
Transformer Cabinet (W x H x D)	44.75" x 82" x 39"					