

MGE UPS SYSTEMS, INC. (MGE) CLAIMS PROPRIETARY RIGHTS IN THE MATERIAL DISCLOSED HEREON. THIS DOCUMENT IS ISSUED FOR ENGINEERING INFORMATION ONLY. IT MAY NOT BE DISCLOSED TO OTHERS NOR MAY IT BE USED FOR MANUFACTURING PURPOSES WITHOUT WRITTEN PERMISSION FROM MGE.

REVISIONS			
REV.	DESCRIPTION	DATE	APPROVED
X0	PROTOTYPE RELEASE	08-06-08	LPG

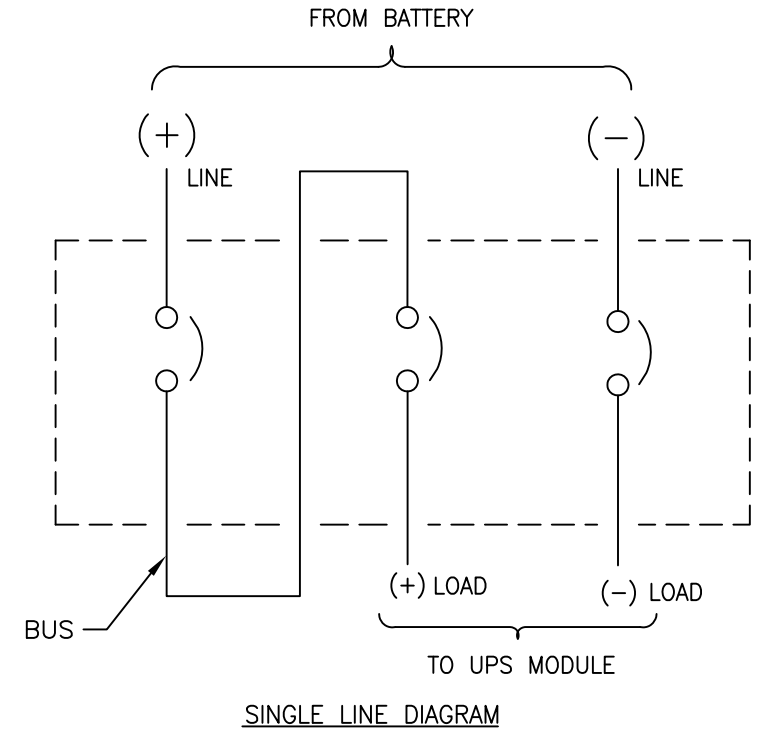

- NOTES:
- UNLESS OTHERWISE SPECIFIED, ALL DIMENSIONS ARE TO THE OUTSIDE EDGE OF THE CABINET, EXCLUDING HARDWARE, CIRCUIT BREAKER, ETC...
 - INDIVIDUALLY ENCLOSED (NEMA 1), THERMAL MAGNETIC, MOLDED CASE CIRCUIT BREAKER, RATED 25KAIC AT 500VDC.
 - COLOR, GRAY (ANSI 49).
 - CONTROL WIRES MUST BE RUN IN INDIVIDUAL CONDUIT SEPARATE FROM POWER WIRES.
 - LUGS, LINE AND LOAD, WILL ACCOMMODATE SIX (24) 3/0-750 MCM COPPER CABLES. TOTAL OF 12 CONNECTIONS ON LINE AND 12 CONNECTIONS ON LOAD.
 - BATTERY DISCONNECT CABINET IS DESIGNED FOR CABLE ENTRY THROUGH TOP OR BOTTOM OF CABINET.
 - APPROXIMATE WEIGHT: 664 LBS.
 - REFER TO UPS INSTL. DWG. FOR LOCATION OF IBEZ PCA.
 - DO NOT BLOCK FRONT VENT OPENINGS.

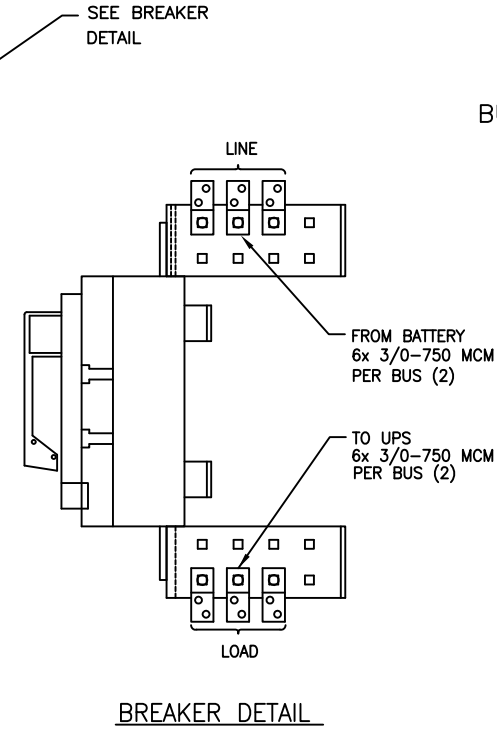
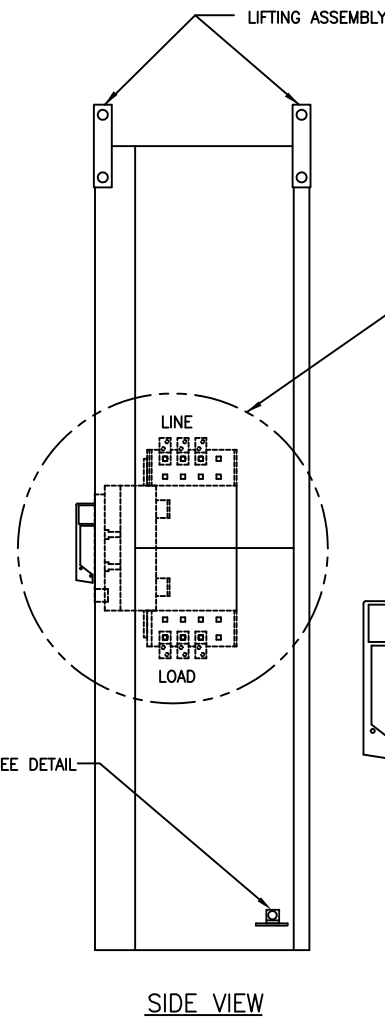
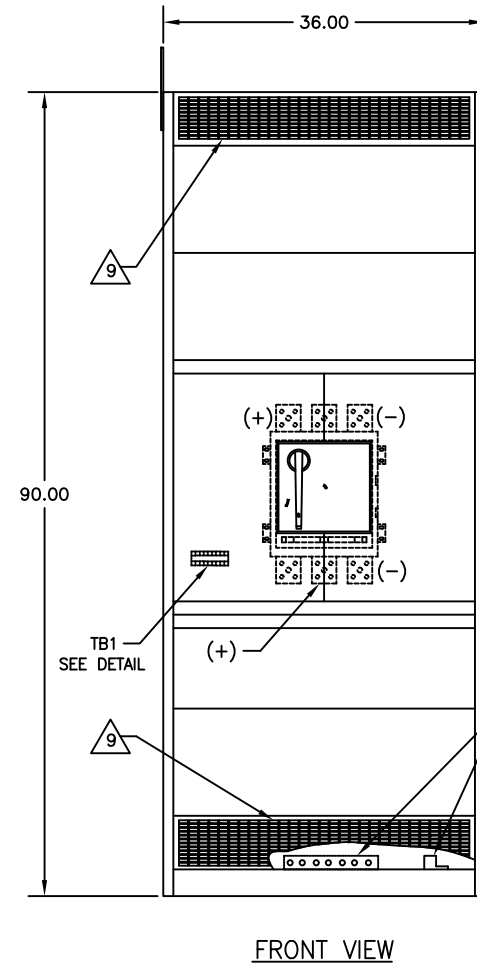
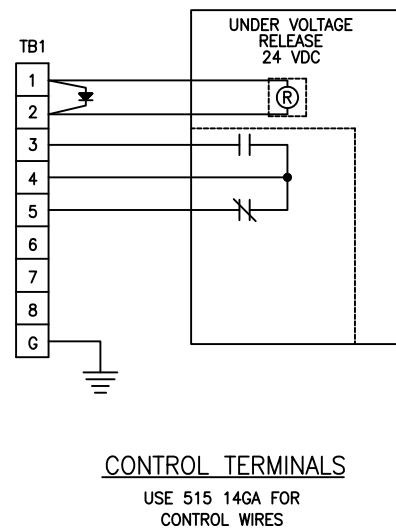
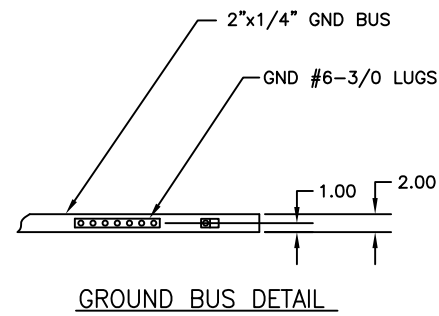
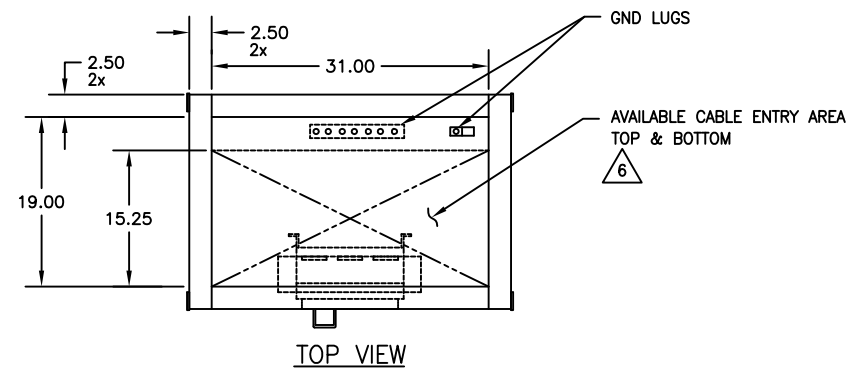
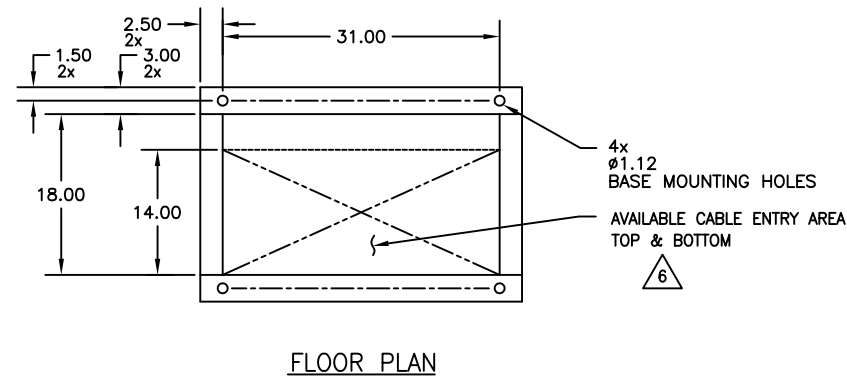
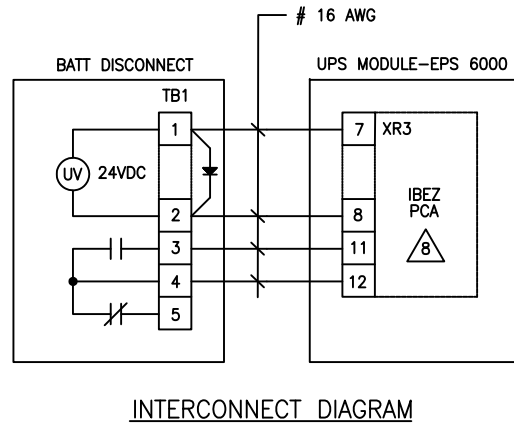

CONTRACT NO.		MGE UPS SYSTEMS		MGE UPS Systems, Inc. 1660 Scenic Avenue Costa Mesa, CA. 92626	
APPROVALS		DATE		INSTALLATION DRAWING BATTERY DISCONNECT (END) 2500A	
DRAWN	LPG	08-06-08			
CHECKED	JCM	08-06-08			
ISSUED	LNA	08-06-08		SIZE	FSCM NO.
				B	9L985
				DWG. NO.	REV.
				90-135265-00	X0
SCALE NONE				SHEET 1 OF 1	