

REVISIONS			
REV	DESCRIPTION	DATE	APPROVED
A00	NEW RELEASE ECN # 285-60	1/27/97	DAN NOEL

MGE UPS SYSTEMS, INC. CLAIMS PROPRIETARY RIGHTS IN THE MATERIAL DISCLOSED HEREIN. THIS DOCUMENT IS ISSUED FOR ENGINEERING INFORMATION ONLY. IT MAY NOT BE DISCLOSED TO OTHERS NOR MAY IT BE USED FOR MANUFACTURING PURPOSES WITHOUT WRITTEN PERMISSION FROM MGE UPS SYSTEMS, INC.

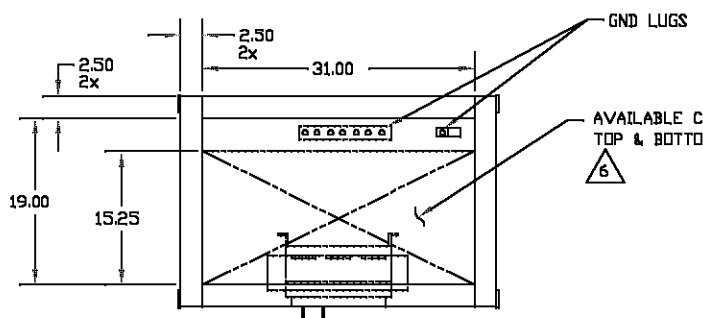

TOP VIEW

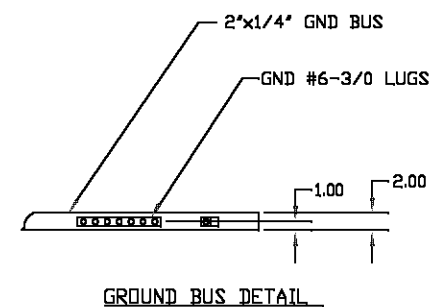

GROUND BUS DETAIL

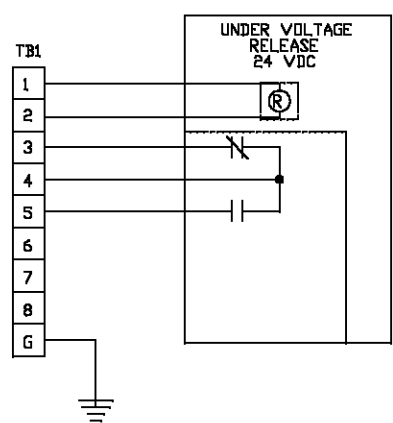

CONTROL TERMINALS  
USE 315 14GA FOR CONTROL WIRES

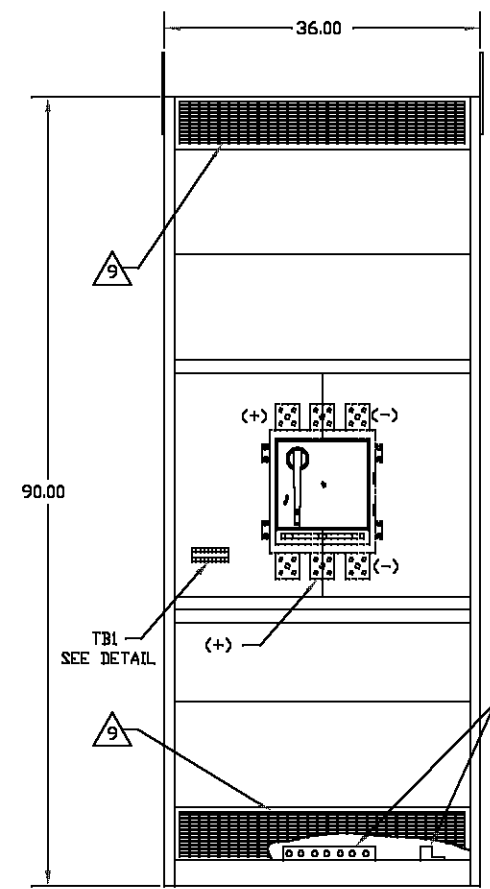

FRONT VIEW

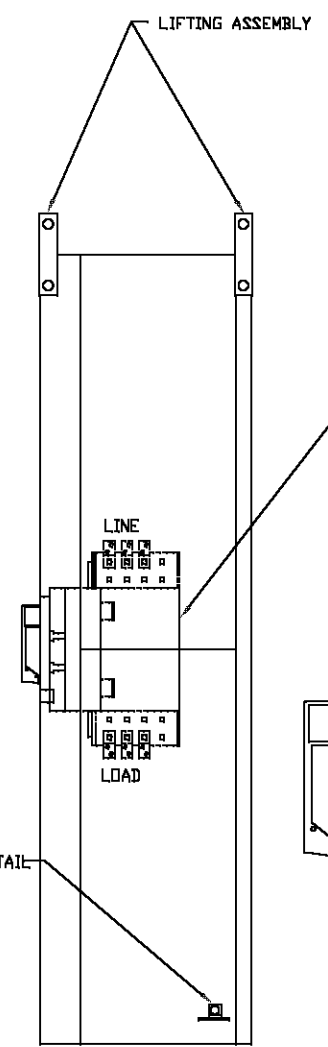

SIDE VIEW

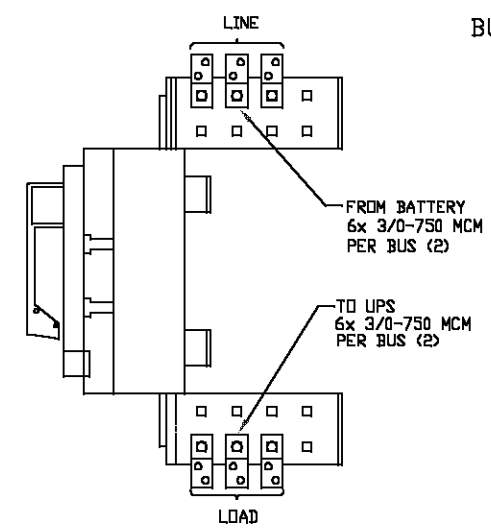

BREAKER DETAIL

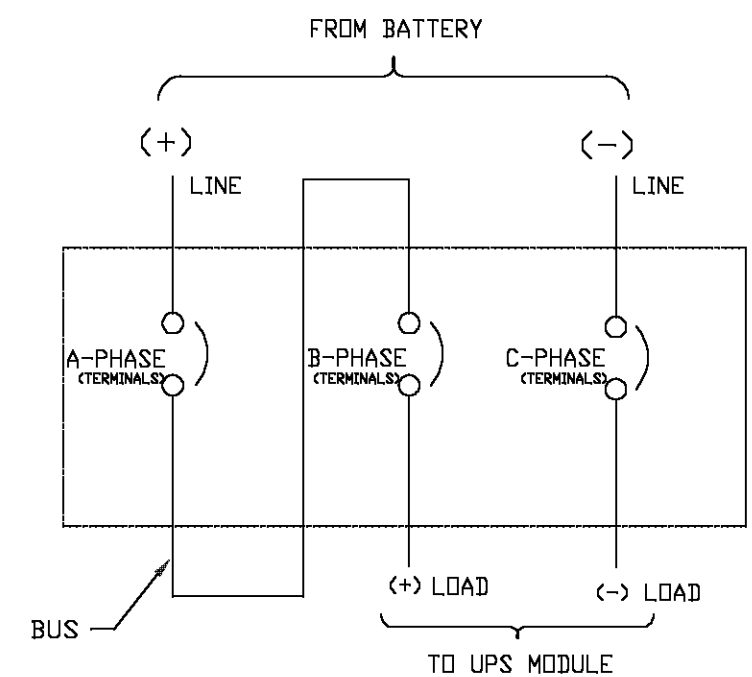

SINGLE LINE DIAGRAM

- NOTES:
- UNLESS OTHERWISE SPECIFIED, ALL DIMENSIONS ARE TO THE OUTSIDE EDGE OF THE CABINET, EXCLUDING HARDWARE, CIRCUIT BREAKER, ETC..
  - INDIVIDUALLY ENCLOSED (NEMA 1), THERMAL MAGNETIC, MOLDED CASE CIRCUIT BREAKER, RATED 25KAIC AT 500VDC.
  - COLOR, GRAY (ANSI 49).
  - CONTROL WIRES MUST BE RUN IN INDIVIDUAL CONDUIT SEPARATE FROM POWER WIRES.
  - LUGS, LINE AND LOAD, WILL ACCOMMODATE SIX (6) 3/0-750 MCM COPPER CABLES. TOTAL OF 12 CONNECTIONS ON LINE AND 12 CONNECTIONS ON LOAD.
  - BATTERY DISCONNECT CABINET IS DESIGNED FOR CABLE ENTRY THROUGH TOP OR BOTTOM OF CABINET.
  - APPROXIMATE WEIGHT: 664 LBS.
  - REFER TO UPS INSTL. DWG. FOR LOCATION OF IBEZ PCA.
  - DO NOT BLOCK FRONT VENT OPENINGS.

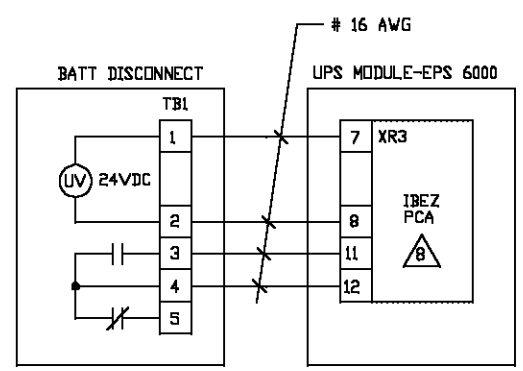

INTERCONNECT DIAGRAM

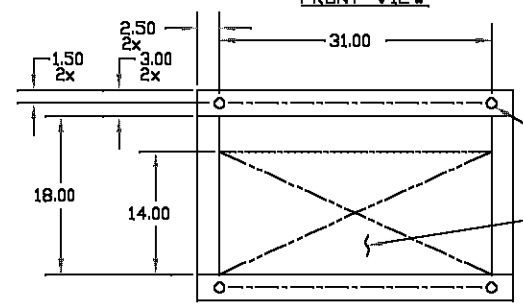

FLOOR PLAN

UNLESS OTHERWISE SPECIFIED DIMENSIONS ARE IN INCHES AND (MILLIMETERS). TOLERANCES ARE:		CONTRACT NO.	
DECIMALS	(MILLIMETERS)	APPROVALS	DATE
.X=±	.X=±	J. FLORES	1/9/97
.XX=±	.X=±	J. MARTINEC	1/27/97
.XXX=±	.XX=±	ISSUED	
ANGLES ±	MATERIAL	DO NOT SCALE	
FINISH		SIZE	CAGE CODE
		B	9L985
		DWG NO.	REV.
		90-130870-00	A00
		SCALE	SHEET 1 OF 1
		90130\870001	

**MGE** UPS SYSTEMS  
MGE UPS Systems, Inc.  
1660 Scenic Avenue  
Costa Mesa, CA. 92626 U.S.A.

**INSTALLATION DRAWING**  
**BATTERY DISCONNECT-EP6000**  
**1600A**

90-130870-00  
SHEET 1 OF 1