

EPE TECHNOLOGIES, INC. (EPE) CLAIMS PROPRIETARY RIGHTS IN THE MATERIAL DISCLOSED HEREON. THIS DOCUMENT IS ISSUED FOR ENGINEERING INFORMATION ONLY. IT MAY NOT BE DISCLOSED TO OTHERS NOR MAY IT BE USED FOR MANUFACTURING PURPOSES WITHOUT WRITTEN PERMISSION FROM EPE.

REVISIONS				
ZONE	REV.	DESCRIPTION	DATE	APPROVED
	A00	NEW RELEASE PER ECN 273-88	04-04-95	N.YOUNES
	B00	REVISED PER ECN		

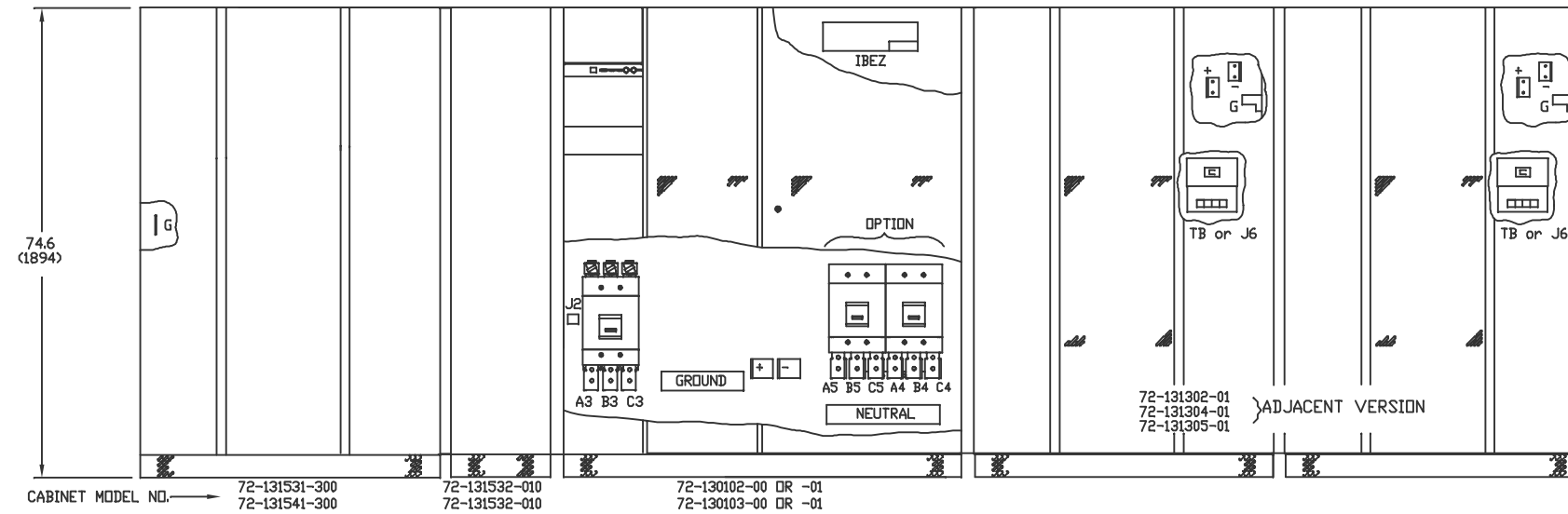
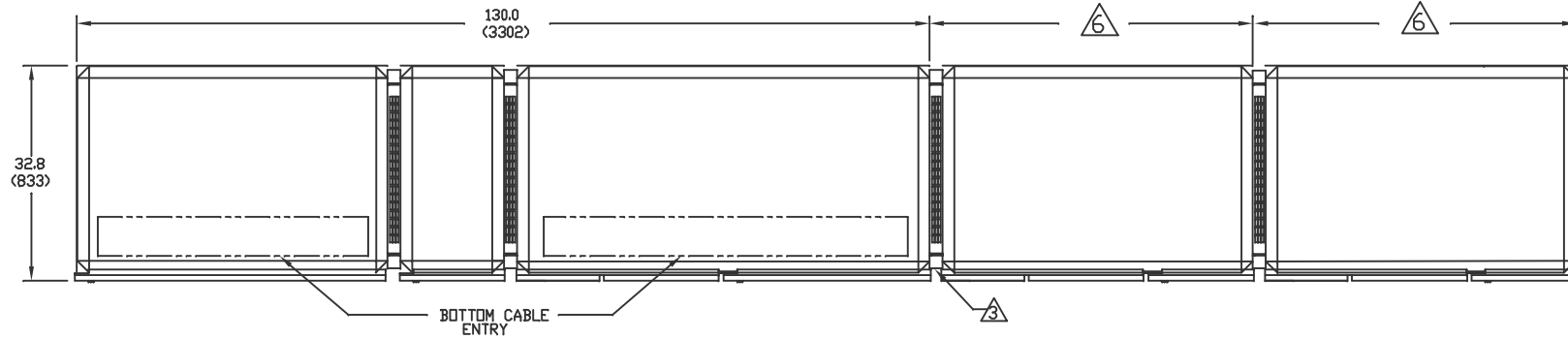

CUSTOMER IS RESPONSIBLE FOR CONNECTING ALL EPE SUPPLIED CABLES. BATTERY CABLE VOLTAGE DROP SHALL BE KEPT TO LESS THAN 0.5VDC BASED ON QF1 RATING.

NOTES: UNLESS OTHERWISE SPECIFIED

1. DIMENSIONING FORMAT IS INCHES (mm).
2. ALL DIMENSIONS ARE TO THE OUTSIDE EDGE OF CABINET, EXCLUDING DOOR LOCKS AND ALL HARDWARE.
3. REFER TO SHEET 3 INSTRUCTIONS ON SECURING CABINETS TOGETHER USING HARDWARE PROVIDED.
4. CONTROL WIRING MUST BE ROUTED IN SEPARATE CONDUITS FROM POWER WIRING.
5. GROUND UPS FRAME USING GROUND BUS PROVIDED ACCORDING TO NATIONAL ELECTRIC CODE AND APPLICABLE LOCAL CODES.
6. OPTIONAL. UP TO THREE (3) BATTERY CABINETS. EACH CABINET IS 47.5 in (1208mm) WIDE (STAND-ALONE VERSION), OR 49.5 in (1257mm) WIDE (ADJACENT VERSION).
7. CABINETS ARE JOINED MECHANICALLY USING COPPER STRAPS WHICH ALSO PROVIDE ELECTRICAL GROUND PATH BETWEEN CABINETS. PROPER ALIGNMENT OF ADJACENT CABINETS AND PROPER INSTALLATION OF THESE STRAPS IS CRITICAL TO A SAFE INSTALLATION. SEE SHEET 3, STEP 3.

SYSTEM FEATURES:

- BOTTOM CABLE ENTRY
- INPUT FILTER
- OUTPUT ISOLATION TRANSFORMER
- WITH OR WITHOUT MAINTENANCE BYPASS

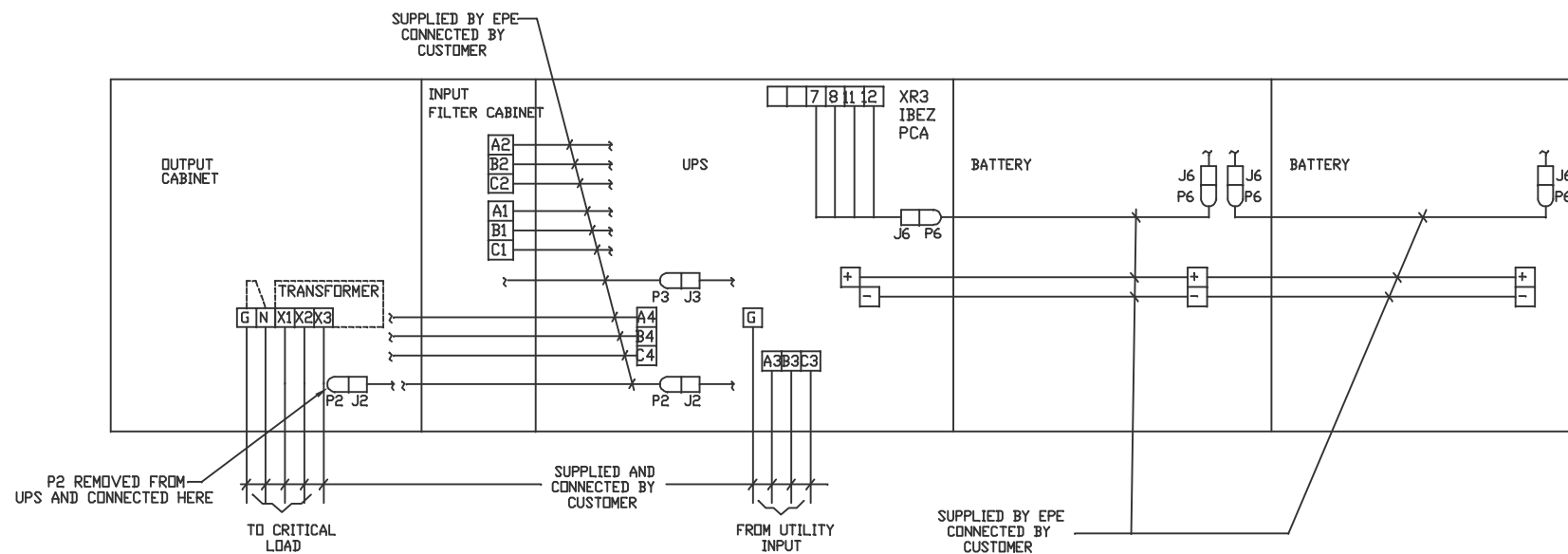

CONTRACT NO.		 EPE TECHNOLOGIES, INC. A subsidiary of Square D Company 1660 SCENIC AVENUE COSTA MESA, CALIFORNIA 92626			
APPROVALS	DATE				
DRAWN V.NEALEY	09-20-94	SYSTEM INSTALLATION 300/375 KVA 480V-208V EPS 6000			
CHECKED N.YOUNES	09-26-94				
ISSUED B.G.A.	09-26-94	SIZE B	FSCM NO. 9L985	DWG. NO. 90-130007-26	REV. B00
		SCALE NONE	CAD FILE: 90130\007261	SHEET 1 of 4	

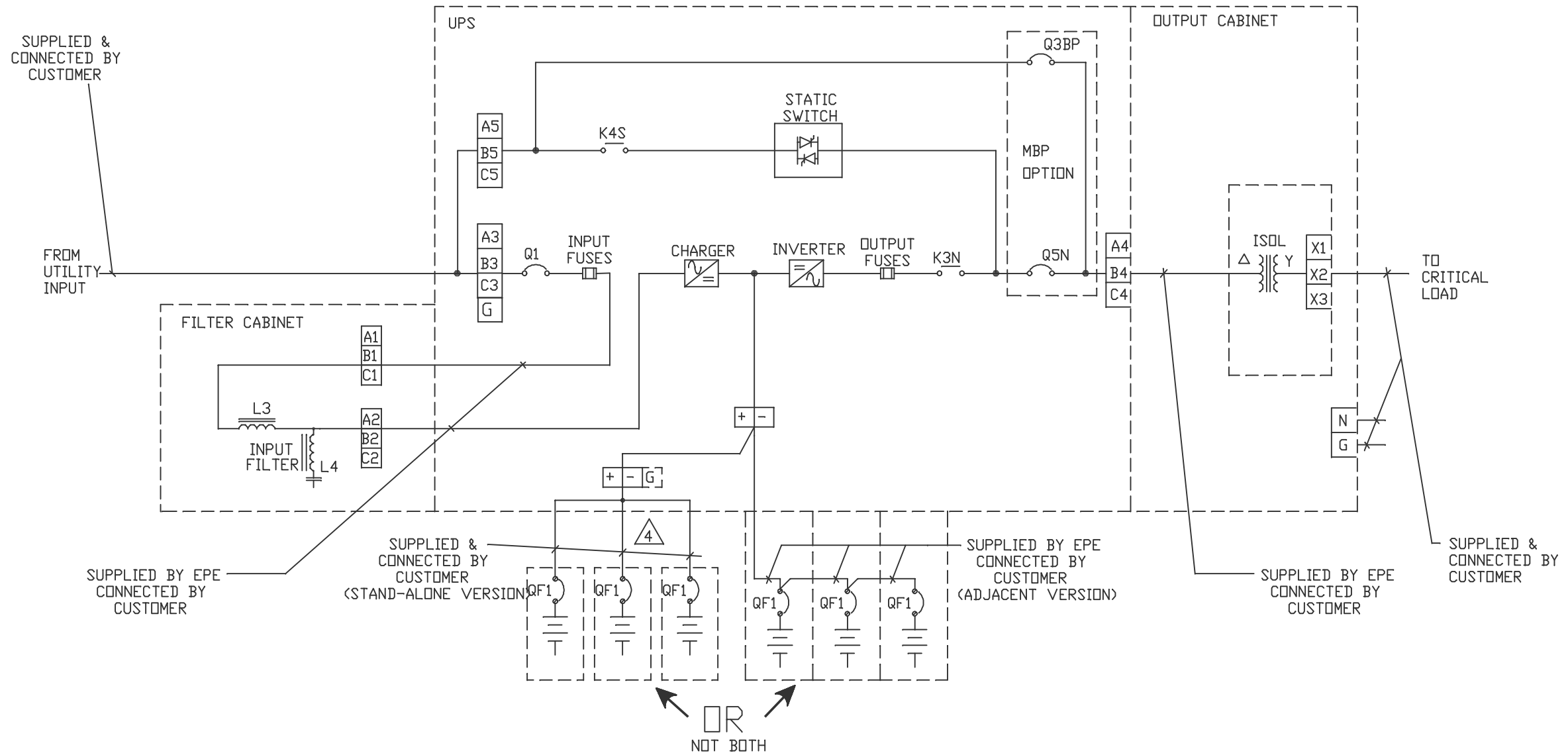

NOTES: UNLESS OTHERWISE SPECIFIED

1. FOLLOW ALL APPLICABLE NEC & LOCAL ELECTRICAL CODES.
2. ALL EXTERNAL WIRING BY OTHERS.
3. INPUT & BYPASS SHALL NOT BE PROVIDED FROM A CORNER GROUNDED DELTA.
4. BATTERY CABLE VOLTAGE DROP SHALL BE KEPT TO LESS THAN 0.5VDC BASED ON QF1 RATING.
5. POWER & CONTROL CABLES SHALL BE IN SEPARATE CONDUITS.

MODEL NO.	QF1
72-131302-01	250A
72-131304-01	250A
72-131305-01	400A

SYSTEM ELECTRICAL CHARACTERISTICS		
RATING @ 0.8 PF LAG	300 KVA	375 KVA
INPUT VOLTAGE NOTE 3	480 VAC, 3PH, 3W+G, 60HZ	480 VAC, 3PH, 3W+G, 60HZ
ROTATION	ABC CLOCKWISE	ABC CLOCKWISE
INPUT CURRENT		
BATTERY FULLY CHARGED	400 AMPS	490 AMPS
BATTERY CHARGING	430 AMPS	540 AMPS
OUTPUT VOLTAGE	208 VAC, 3PH, 4W+G, 60HZ	208 VAC, 3PH, 4W+G, 60HZ
OUTPUT CURRENT (FULL LOAD)	833 AMPS	1041 AMPS
DC FLOAT VOLTAGE (MAX)	545 VDC	545 VDC
DC NOMINAL VOLTAGE	480 VDC	480 VDC
DC CUT-OFF VOLTAGE (MIN)	390 VDC	390 VDC
Q1 RATING	600 AMPS	700 AMPS
K4S RATING	420 AMPS (IEC RATED: 500A)	420 AMPS (IEC RATED: 500A)
BATTERY DISCONNECT (QF1)	⚠	⚠
Q3BP/Q5N (OPTIONAL)	500 AMPS	600 AMPS

SIZE	FSCM NO.	DWG. NO.	REV.
B	9L985	90-130007-26	B00
SCALE NONE	CAD FILE: 90130\007262	SHEET 2 of 4	

CABINET INSTALLATION INSTRUCTIONS

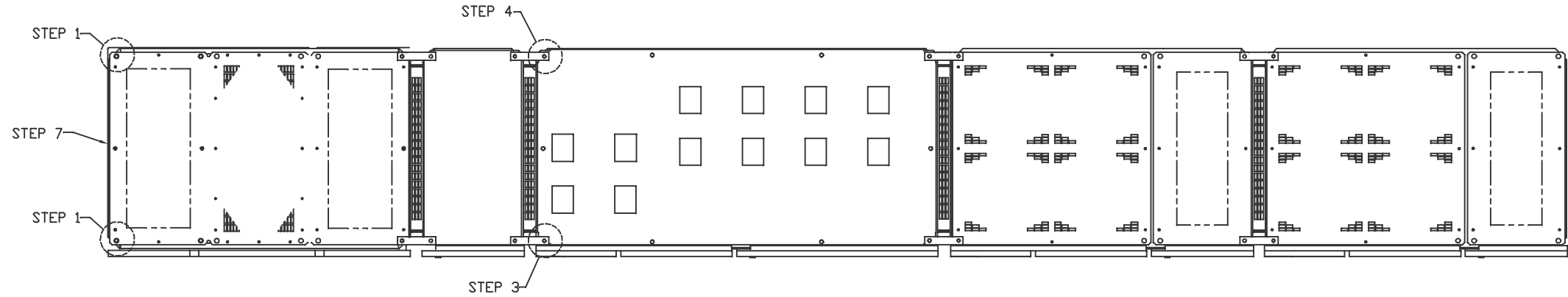

AUXILIARY CABINET INSTRUCTIONS:

USE THESE INSTRUCTIONS IN CONJUNCTION WITH THE INSTALLATION MANUAL.

BEFORE BEGINNING THIS SEQUENCE, THE UPS MUST BE IN ITS APPROXIMATE FINAL POSITION AND THE LEFT SIDE PAINTED PANEL OF THE UPS CABINET MUST BE REMOVED.

- STEP 1: REMOVE M16 BOLTS, STRAP & WASHER FOR RE-USE. (SEE FIGURE)
- STEP 2: ALIGN THE TWO CABINETS TOGETHER AS CLOSELY AS POSSIBLE. ROUTE ALL POWER AND CONTROL CABLES THROUGH THE SIDE OF THE ADJACENT CABINET.
- STEP 3: ALIGN THE FRONT STRAP TO THE ADJACENT CABINET AND INSTALL THE FIRST BOLT & WASHER IN THE HOLE AT THE FRONT OF THE CABINET. USE LEVELERS TO ASSIST IN LINING UP THE CABINETS. INSTALL HARDWARE FINGER TIGHT. (SEE FIGURE)
- STEP 4: ALIGN THE REAR STRAP AND INSTALL THE NEXT BOLT AND WASHER IN THE HOLE AT THE REAR OF THE CABINET. INSTALL HARDWARE FINGER TIGHT. (SEE FIGURE)
- STEP 5: TIGHTEN ALL BOLTS CONNECT ALL CABLES.
- STEP 6: REPEAT STEPS 1-4 FOR EACH ADDITIONAL AUXILIARY CABINET.
- STEP 7: INSTALL THE LEFT SIDE PAINTED PANEL TO THE AUXILIARY CABINET.

ADJACENT BATTERY CABINET INSTALLATION:

SIMILAR TO AUXILIARY CABINET INSTALLATION.

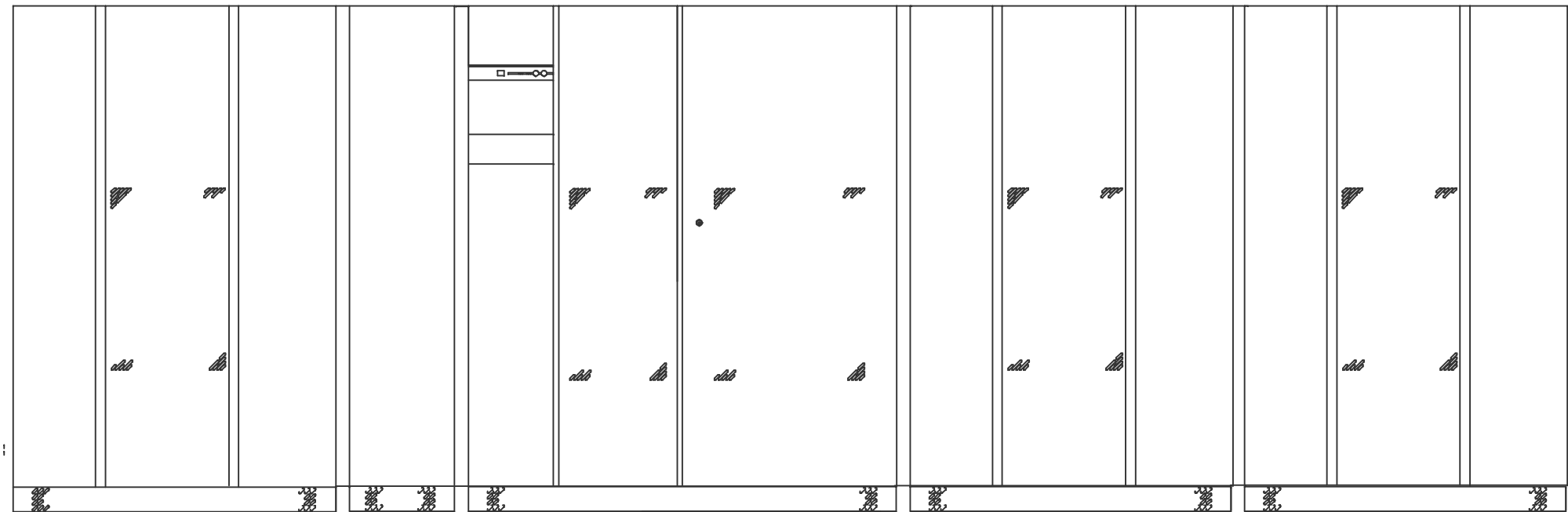

AUXILIARY CABINET FILTER CABINET UPS ADJACENT BATTERY CABINETS

LEVELER	DIMENSION					
	A	B	C	D	E	F
CENTER	1.26 (32)	28.99 (736)	4.44 (113)	44.74 (1136)	60.84 (1545)	13.25 (337)
TANGENT	.08 (2)	31.35 (796)	47.10 (1196)	62.84 (1596)	2.00 (51)	15.69 (399)

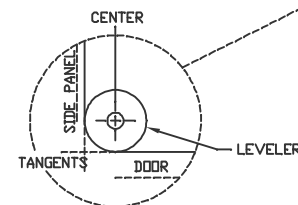
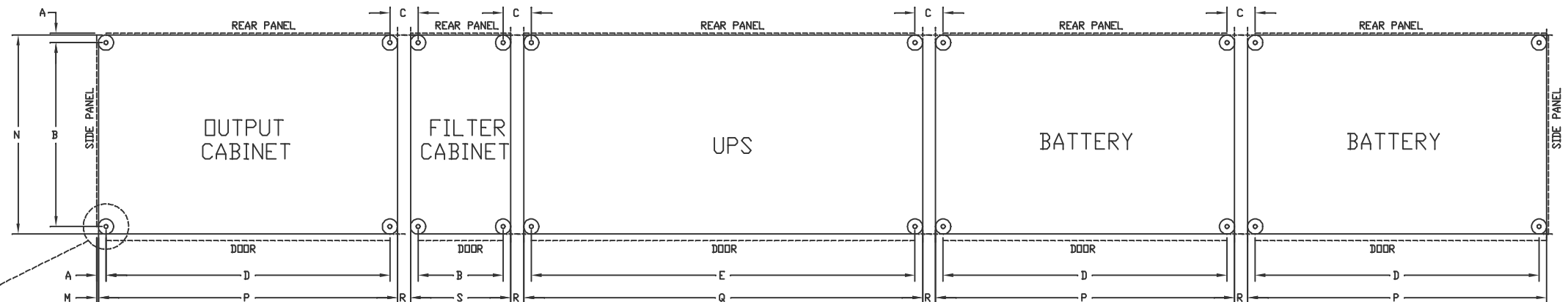

SIZE	FSCM NO.	DWG. NO.	REV.
B	9L985	90-130007-26	B00
SCALE NONE	CAD FILE: 90130\007263	SHEET 3	of 4

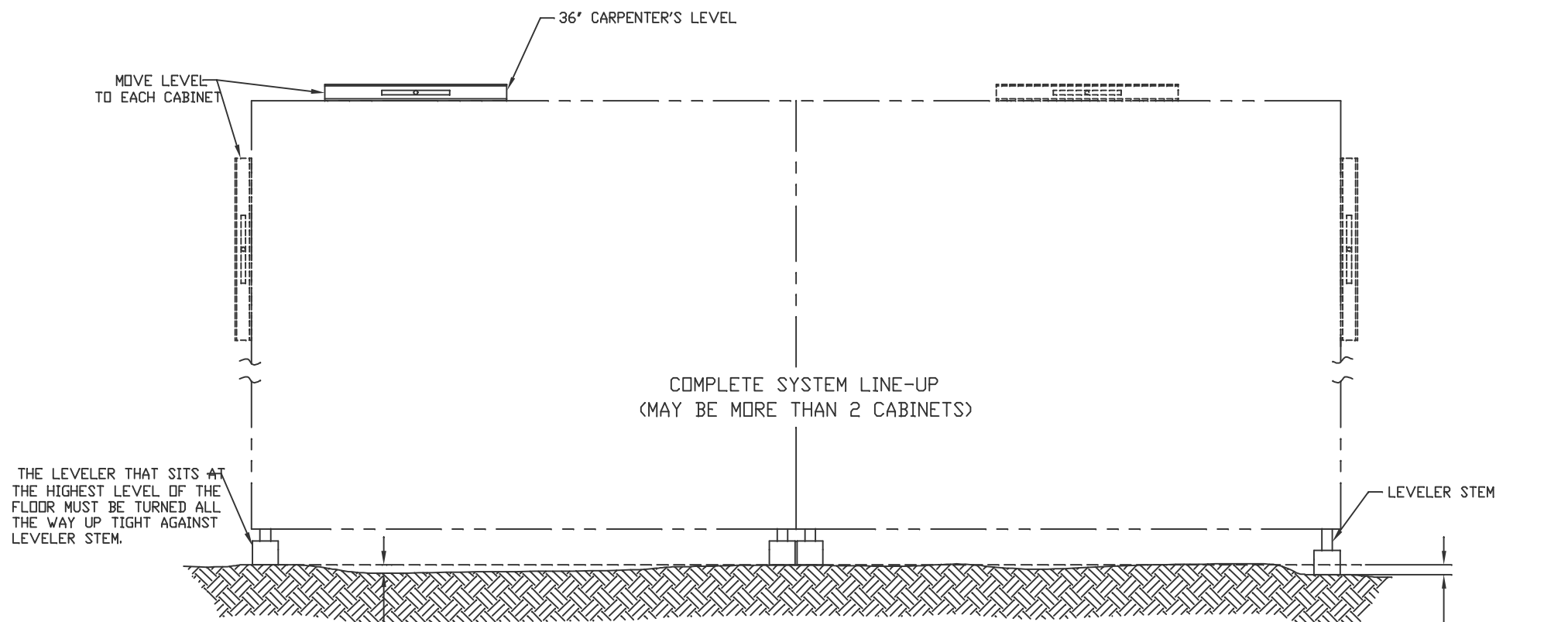

THE LEVELER THAT SITS AT THE HIGHEST LEVEL OF THE FLOOR MUST BE TURNED ALL THE WAY UP TIGHT AGAINST LEVELER STEM.

THE VERTICAL DISTANCE BETWEEN THE HIGHEST AND THE LOWEST AREA OF THE FLOOR WHERE THE LEVELERS WILL SET MUST NOT BE MORE THAN 5/8". FOR DISTANCES MORE THAN 5/8", SHIMS ARE REQUIRED.

MAXIMUM ALLOWABLE LEVELER TRAVEL = 5/8" (DRAWING IS EXAGGERATED TO SHOW RELATIVE POSITION).

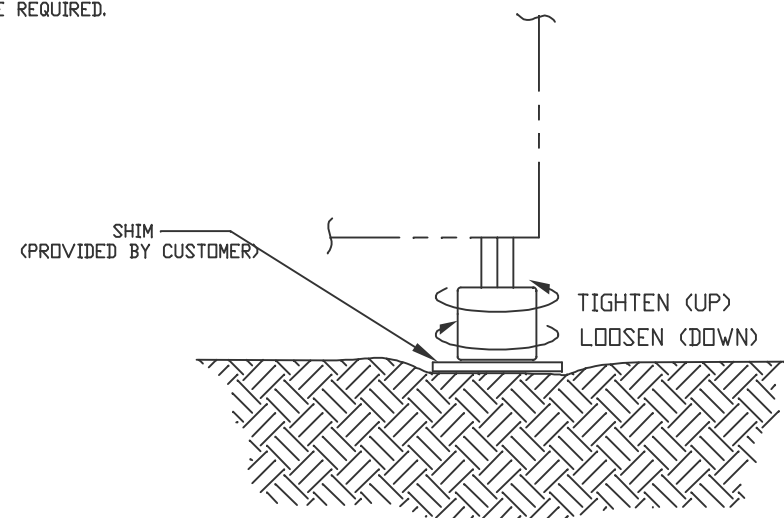

NO. OF TURNS	VERTICAL TRAVEL IN. (mm)
1/4	0.020 (0.5)
1/2	0.034 (1)
3/4	0.059 (1.5)
1	0.079 (2)
2	0.157 (4)
3	0.236 (6)
4	0.315 (8)
5	0.394 (10)
6	0.472 (12)
7	0.5512 (14)

FACTS TO KNOW DURING FLOOR PREPARATION:

- * FOR EASE OF CABINET INSTALLATION, IT IS RECOMMENDED THAT FLOOR MUST BE LEVEL (NO GRADE).
- * TO AVOID USING SHIMS DURING INSTALLATION, PREPARE THE FLOOR FOUNDATION SUCH THAT THE DIFFERENCE BETWEEN THE HIGHEST AND LOWEST PORTIONS OF THE FLOOR OF THE COMPLETE SYSTEM IS NOT MORE THAN 5/8".

FACTS TO KNOW BEFORE LEVELING:

- * DO NOT USE A WRENCH OR ANY TOOL TO TURN THE LEVELERS DURING THE LEVELING PROCESS. A LIFTING DEVICE OR JIG MUST BE USED WHILE TURNING LEVELERS. A PIPE WRENCH MAY ONLY BE USED TO LOOSEN THE LEVELERS FROM THE LEVELER STEM.
- * MAXIMUM ALLOWABLE LEVELER TRAVEL = 5/8". FOR ADJUSTMENTS OF MORE THAN 5/8", USE A SHIM POSITIONED UNDER THE PROPER LEVELER.
- * THE THREADED PART OF LEVELER STEM ATTACHED TO THE CABINET FRAME IS PROVIDED WITH THREAD-LOCKING COMPOUND TO PREVENT IT FROM TURNING WHEN LEVELERS ARE ADJUSTED.
- * REMOVAL AND INSTALLATION OF PANELS MAY BE DIFFICULT IF A CABINET IS NOT LEVEL.
- * TOOL REQUIRED: 36" CARPENTER'S LEVEL

LEVELING OF UPS AND STAND-ALONE BATTERY CABINETS:

1. POSITION THE CABINET AT ITS FINAL LOCATION.
2. DETERMINE WHICH LEVELER WILL SET AT THE HIGHEST AREA OF THE FLOOR. TURN THIS LEVELER #1 ALL THE WAY UP TIGHT AGAINST THE LEVELER STEM. A LIFTING DEVICE OR JIG MUST BE USED TO ALLOW THE LEVELER TO TURN FREELY.
3. DETERMINE WHICH LEVELER IS CLOSEST TO LEVELER #1. WITH A CARPENTER'S LEVEL SET ON THE CABINET'S HORIZONTAL FRAME, ADJUST THIS LEVELER #2 UNTIL THIS SIDE IS LEVEL.
4. DETERMINE THE NEXT FURTHEST LEVELER TO LEVELER #1. WITH A CARPENTER'S LEVEL SET ON THE CABINET'S HORIZONTAL FRAME, ADJUST THIS LEVELER #3 UNTIL THIS SIDE IS LEVEL.
5. DETERMINE THE FURTHEST LEVELER TO LEVELER #1. WITH A CARPENTER'S LEVEL SET ON THE CABINET'S HORIZONTAL FRAME, ADJUST THIS LEVELER #4 UNTIL THIS SIDE IS LEVEL.

LEVELING OF AUXILIARY CABINETS OR BATTERY CABINETS ADJACENT TO UPS:

1. POSITION THE CABINET CLOSE TO THE UPS.
2. ADJUST THE TWO LEVELERS CLOSEST TO THE UPS UNTIL THE TOP OF THIS CABINET IS EVEN WITH THE UPS.
3. WITH A CARPENTER'S LEVEL SET ON THE CABINET'S HORIZONTAL FRAME, ADJUST THE OTHER TWO LEVELERS UNTIL THE CABINET IS LEVEL.
4. INSTALL THE GROUNDING STRAPS AS DESCRIBED IN A SEPARATE INSTRUCTION.
5. TIGHTEN ALL STRAP BOLTS AFTER LEVELING IS COMPLETE FOR ALL CABINETS.

SIZE B	FSCM NO. 9L985	DWG. NO. 90-130007-26	REV. B00
SCALE NONE	CAD FILE: 90130\007264	SHEET 4	OF 4