

MGE UPS SYSTEMS, INC. CLAIMS PROPRIETARY RIGHTS IN THE MATERIAL DISCLOSED HEREIN. THIS DOCUMENT IS ISSUED FOR ENGINEERING INFORMATION ONLY. IT MAY NOT BE DISCLOSED TO OTHERS NOR MAY IT BE USED FOR MANUFACTURING PURPOSES WITHOUT WRITTEN PERMISSION FROM MGE UPS SYSTEMS, INC.

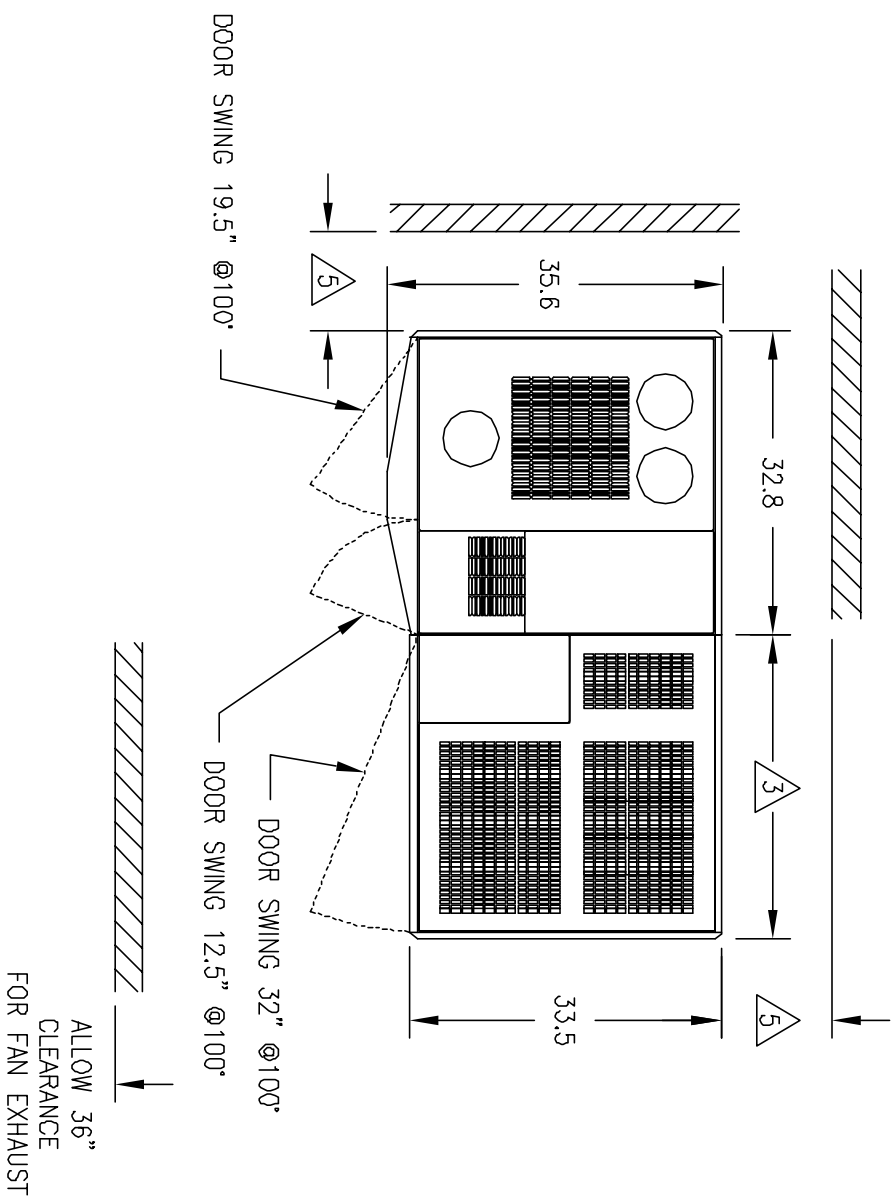

DWG NO. 90-173030-00 SH 1 REV. A01

REVISIONS			
REV	DESCRIPTION	DATE	APPROVED
A00	RELEASE PER ECN-004234	2/15/05	I.K.
A01	REVISED PER ECN-004568	03/08/06	IK

- NOTES: UNLESS OTHERWISE SPECIFIED.
- DIMENSION FORMAT IS IN INCHES.
 - REFER TO EACH INDIVIDUAL CABINET INSTALLATION DRAWING INDICATED BELOW.
 - 90-173020-00 UPS INSTALLATION.
 - 90-173021-00 BATTERY CABINET INSTALLATION.
 - OPTIONAL UP TO FOUR (4) BATTERY CABINETS. THEY CAN BE ADJACENT OR STAND ALONE VERSIONS. EACH ADJACENT CABINET IS 25.8"W OR 32.8"W WITH ONE OUTSIDE PANEL. EACH STAND ALONE CABINET IS 26.5"W OR 33.5"W.
 - CUSTOMER IS RESPONSIBLE FOR CONNECTING ALL MGE SUPPLIED CABLES.
 - 1.0" MINIMUM CLEARANCE TO WALL REQUIRED. 6.0" SIDE CLEARANCE REQUIRED WITH SEISMIC BRACKETS.
 - CABINETS ARE ATTACHED TOGETHER USING C-BRACKETS.

UNLESS OTHERWISE SPECIFIED DIMENSIONS ARE IN INCHES AND [MILLIMETERS]. TOLERANCES ARE: DECIMALS [MILLIMETERS] X=# X=# XX=# XX=# XXX=# XXX=#		CONTRACT NO.		MGE UPS Systems, Inc. 1660 Scenic Avenue Costa Mesa, CA. 92626 U.S.A.	
MATERIAL		APPROVALS		SYSTEM INSTALLATION UPS AND BATTERY GALAXY 4000 40-75KVA	
ANGLES ±		DRAWN H.DO		SIZE CAGE CODE DWG NO.	
FINISH		CHECKED I.K.		B 91985 90-173030-00	
		ISSUED I.K.		SCALE N/A CAD SHEET 1 OF 3	
		DO NOT SCALE DRAWING		REV. A01	

GALAXY 4000 UPS SYSTEM WITH BATTERY SINGLE LINE DIAGRAM

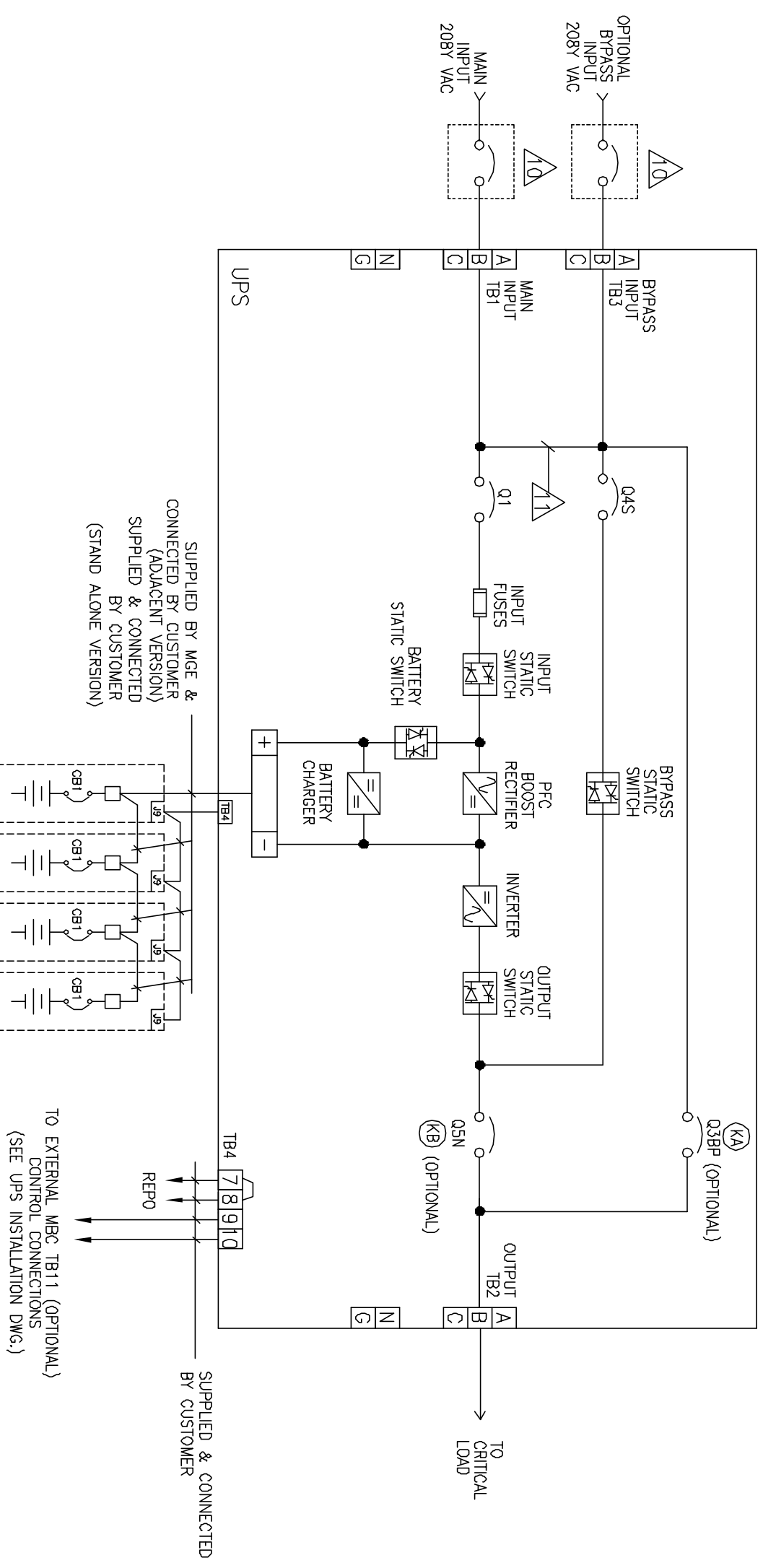

NOTES: UNLESS OTHERWISE SPECIFIED.

7. FOLLOW ALL APPLICABLE NEC AND LOCAL ELECTRICAL CODES.
8. ALL EXTERNAL WIRING BY OTHERS.
9. POWER AND CONTROL CABLES SHALL BE IN SEPARATE CONDUITS.
- ▲ UPSTREAM PROTECTIVE DEVICE REQUIRED. PROVIDED BY OTHERS.
- ▲1 PROVIDED WITH SINGLE INPUT.

12. CABINET WEIGHTS: UPS: 40/50KVA: 1060 LBS, 65/75KVA: 1235 LBS.
BATTERY: REFER TO BATTERY CABINET INSTALLATION DRAWING 90-173021-00.

SIZE	CAGE CODE	DWG NO.	REV.
B	9L985	90-173030-00	A01
SCALE	NONE	CAD	SHEET 2

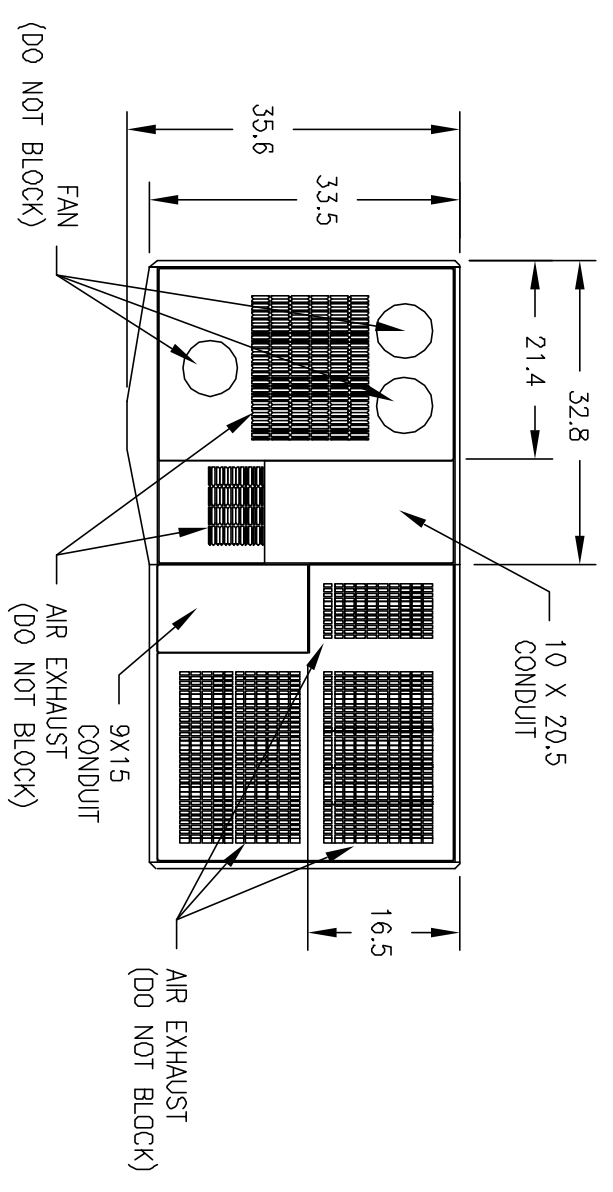

TOP ENTRY CONDUIT LOCATIONS

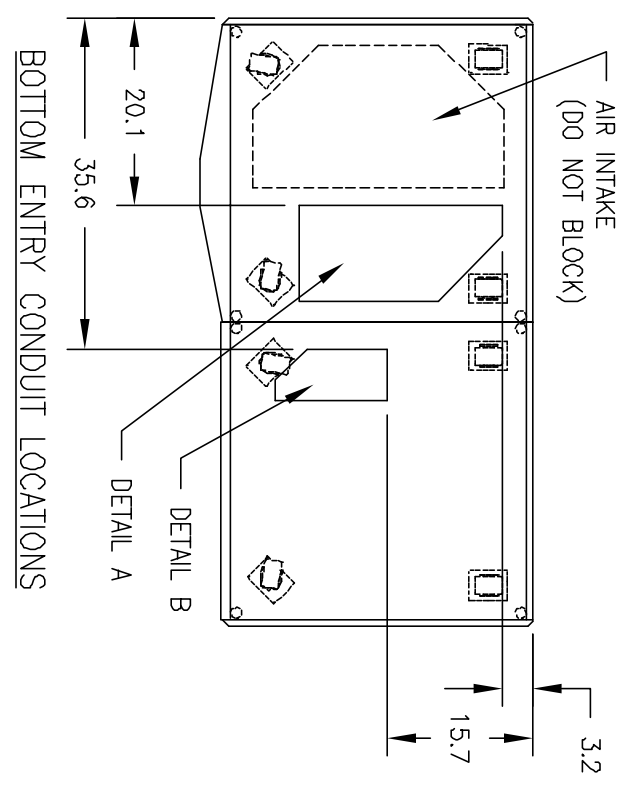

BOTTOM ENTRY CONDUIT LOCATIONS

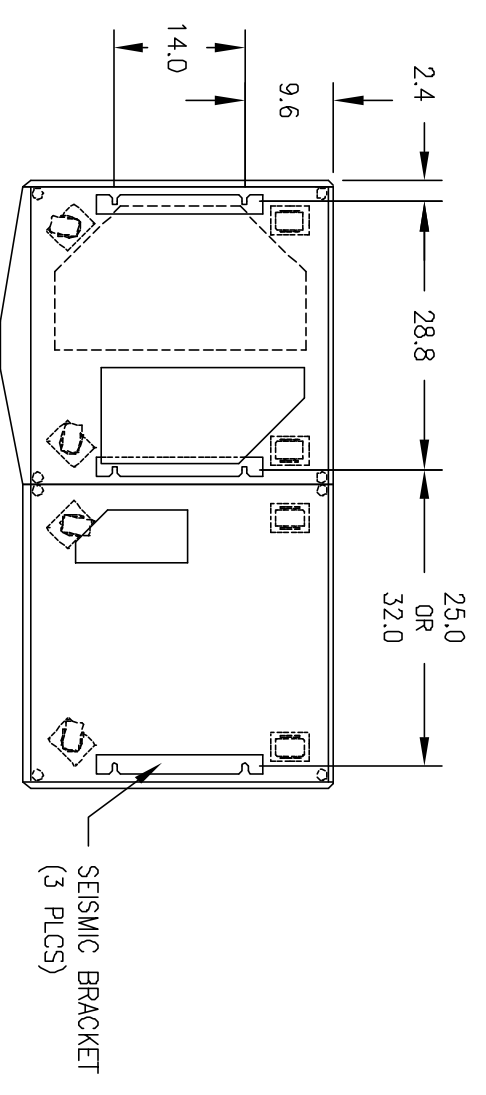

SEISMIC BRACKET LOCATIONS

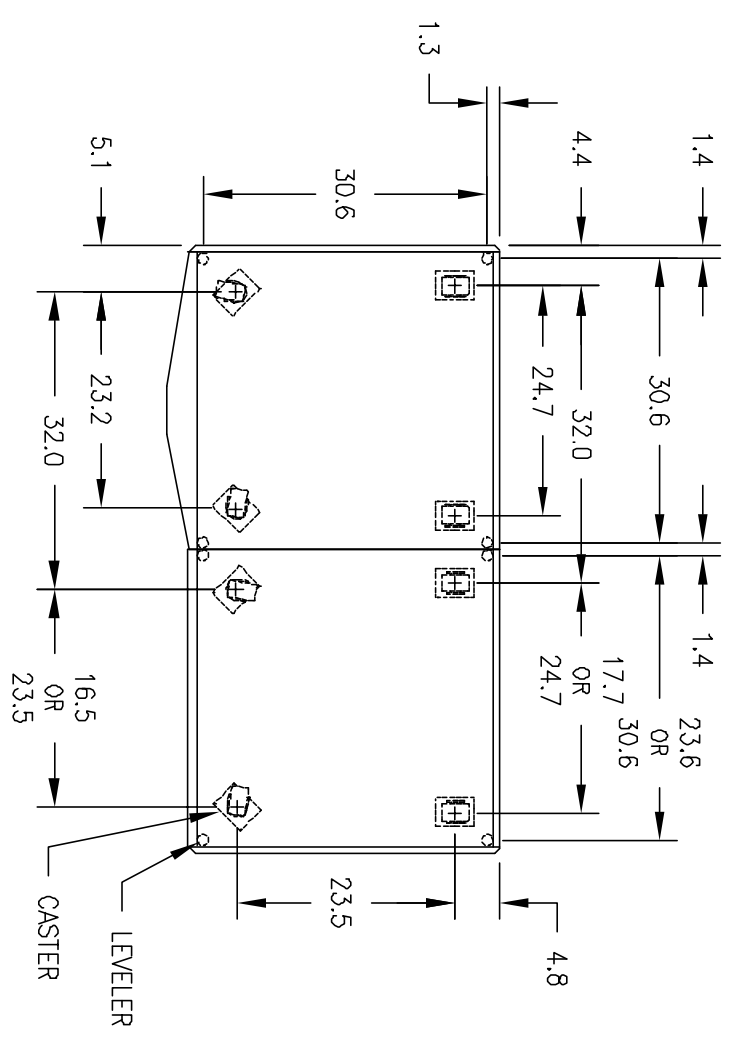

CASTER & LEVELER LOCATIONS

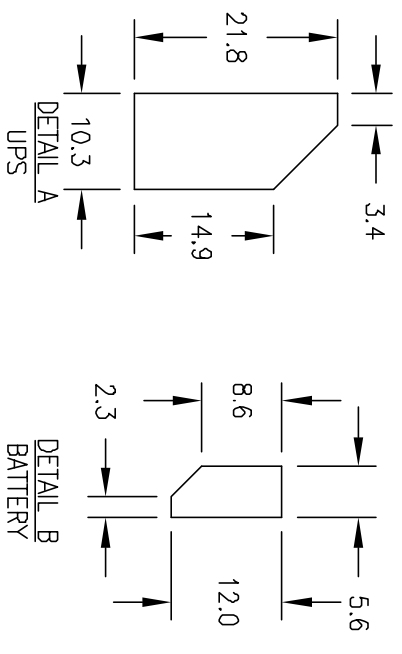

DETAIL A
UPS

DETAIL B
BATTERY

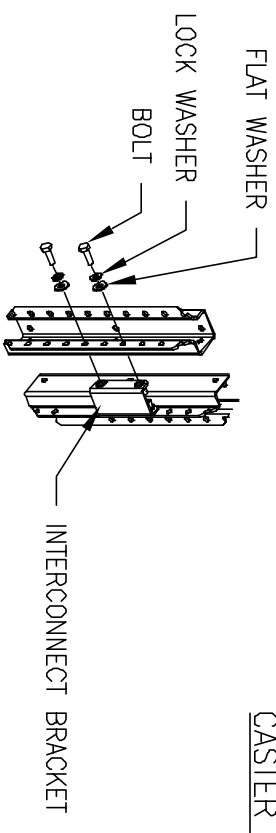

DETAIL
CABINET INTERCONNECT BRACKET
(PRE-ATTACHED TO L.H. SIDE OF BATTERY CABINET)

SIZE	CAGE CODE	DWG NO.	REV.
B	9L985	90-173030-00	A01
SCALE	NONE	CAD	SHEET
			3