

MGE UPS SYSTEMS, INC. (MGE) CLAIMS PROPRIETARY RIGHTS IN THE MATERIAL DISCLOSED HEREON. THIS DOCUMENT IS ISSUED FOR ENGINEERING INFORMATION ONLY. IT MAY NOT BE DISCLOSED TO OTHERS NOR MAY IT BE USED FOR MANUFACTURING PURPOSES WITHOUT WRITTEN PERMISSION FROM MGE.

SYSTEM DIMENSIONS

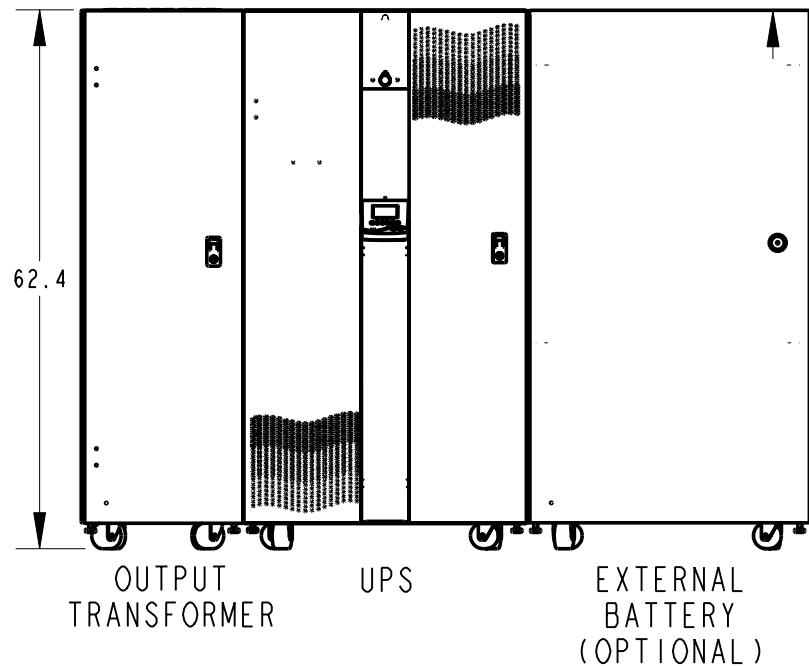
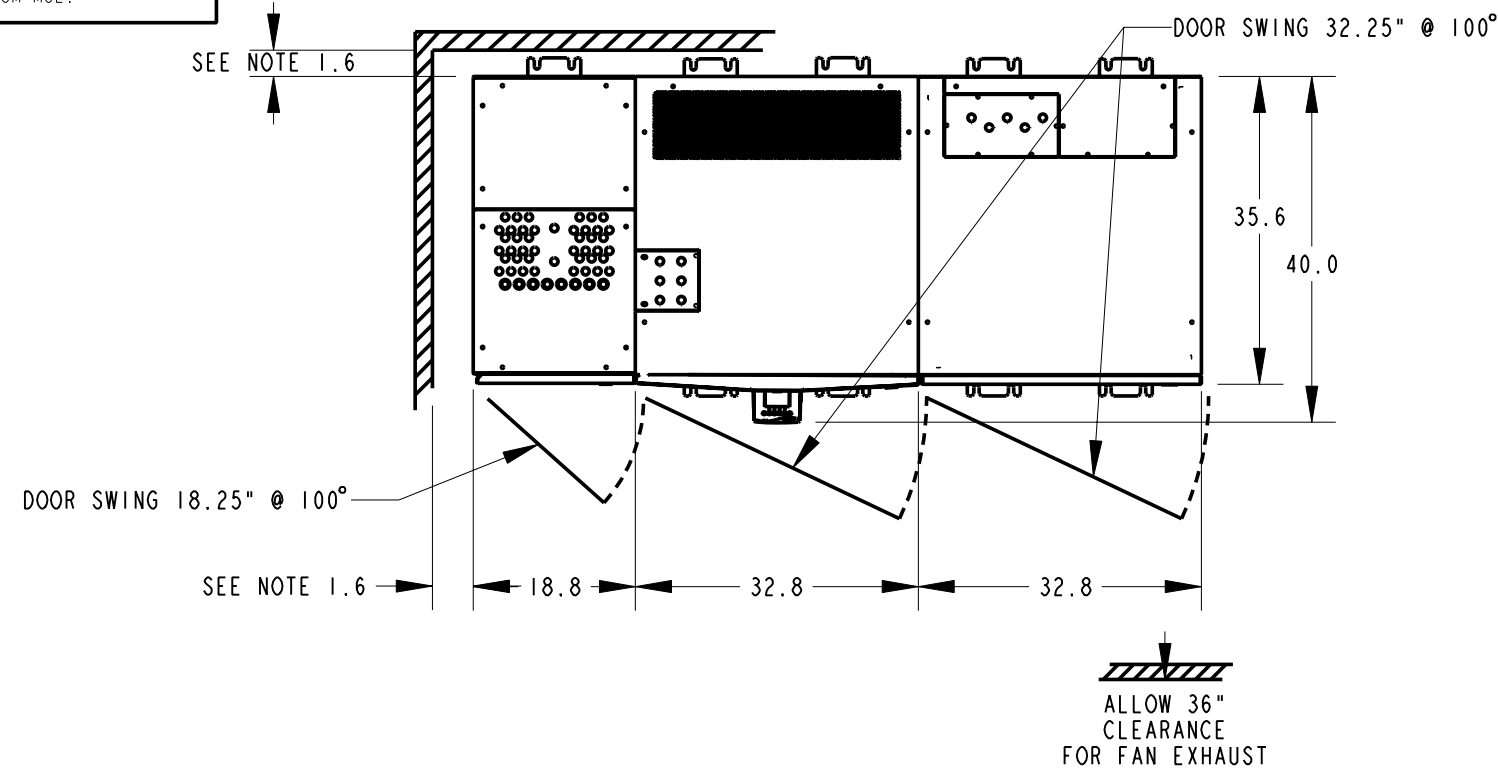

REVISIONS				
ZONE	REV	DESCRIPTION	DATE	APPROVED
	A00	RELEASED PER ECN-003817	3-18-04	I. KENNEDY
	B00	RELEASED PER ECN-004297	01-06-06	B. K.
	B01	REVISED CHART; SEE ECN-004992	23OCT06	JRS

TABLE I

	UPS CABINET WEIGHTS (LBS.)			
	10-15KVA		20-30KVA	
	W/INPUT XFMR	NO INPUT XFMR	W/INPUT XFMR	NO INPUT XFMR
NO BATTERIES	1032	742	1185	785
LEVEL 1 BATTERY	1322	1032	1475	1075
LEVEL 2 BATTERY	1549/1716	1302/1469	1702/1869	1302/1469
LEVEL 3 BATTERY	1832/1892	1542/1602	1832/1892	1585/1645
LEVEL 4 BATTERY	2182/2412	1935/2165	2395/2565	1935/2165

- 1.1. DIMENSION FORMAT IS IN INCHES.
- 1.2. COLOR: MGE LIGHT GRAY.
- 1.3. CABINET WEIGHTS: UPS: SEE TABLE I, OUTPUT TRANSFORMER: 410 LBS. EXTERNAL BATTERY: 1940 LBS. MIN/2723 LBS. MAX.
- 1.4. RECOMMENDED OPERATING RANGE: 60°F (15°C TO 77°F (25°C) REFER TO SPECS FOR HIGHER TEMPERATURE. HEAT REJECTION FROM TOP OF CABINETS.
- 1.5. IF STORING UPS FOR MORE THAN THREE MONTHS, UPS SHOULD BE POWERED UP FOR 8 HOURS MIN. EVERY THREE MONTHS TO PREVENT DAMAGE TO BATTERIES.
- 1.6. IF INSTALLED WITH SEISMIC BRACKETS, 4.5" CLEARANCE IS REQUIRED.

NOTES: UNLESS OTHERWISE SPECIFIED.

UNLESS OTHERWISE SPECIFIED DIMENSIONS ARE IN INCHES TOLERANCES ARE: DECIMALS .XX ±.03 .XXX ±.010 ANGLES ± 1/2°	CONTRACT NO.		MGE UPS Systems, Inc. 1660 Scenic Avenue Costa Mesa, CA 92626	
	APPROVALS	DATE		
MATERIAL	DRAWN	H. DO	12-9-03	INSTALLATION DRAWING 10-30KVA UPS AND OUTPUT TRANSFORMER
FINISH	CHECKED	I. K.	12-9-03	
	MFG ENG			
	ISSUED	H. DO	12-9-03	SIZE B FSCM NO. 9L985 DWG. NO. 90-170805-00 REV. B01
SCALE 0.045		90-17080X-XX.1		SHEET 1 OF 3

4 3 2 1

TOP ENTRY CONDUIT LOCATIONS

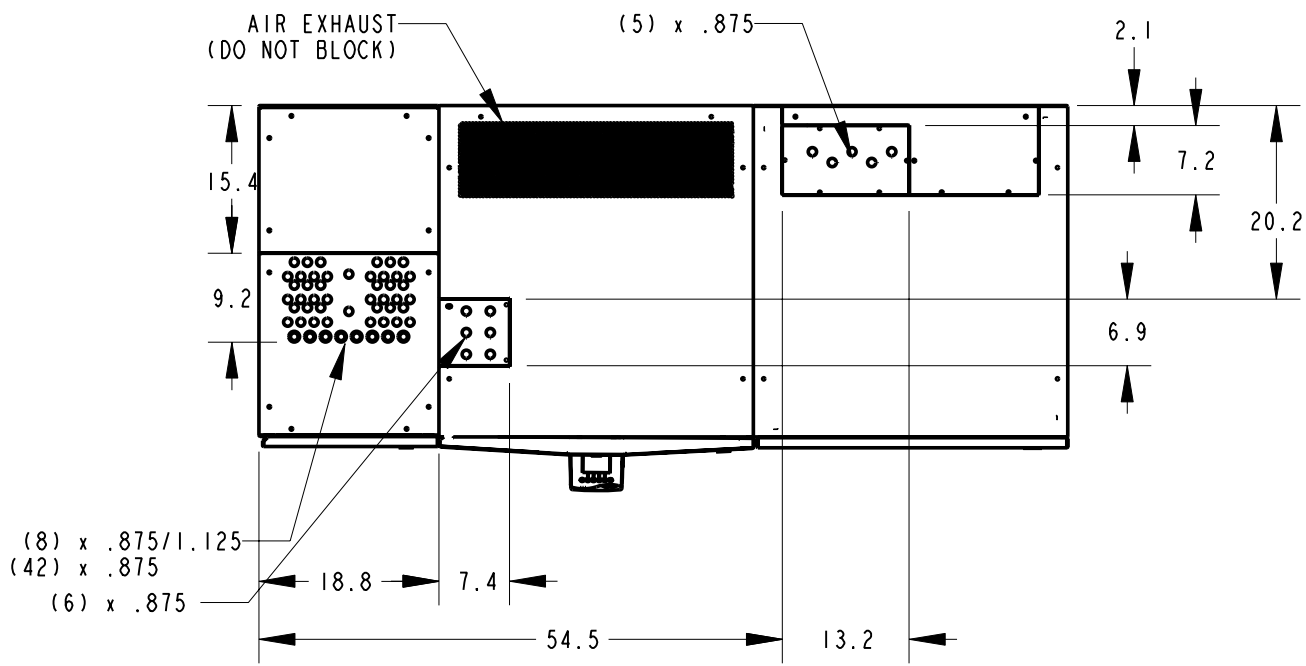

CASTER & LEVELER LOCATIONS

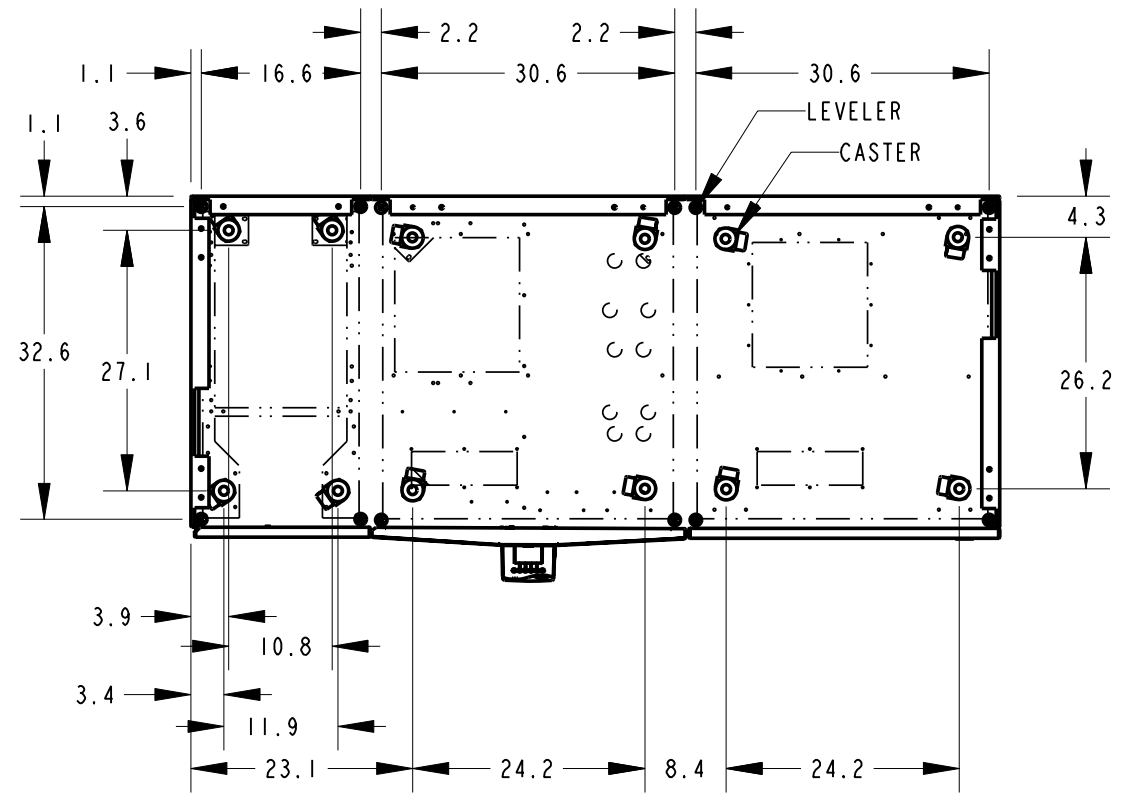

BOTTOM ENTRY CONDUIT LOCATIONS

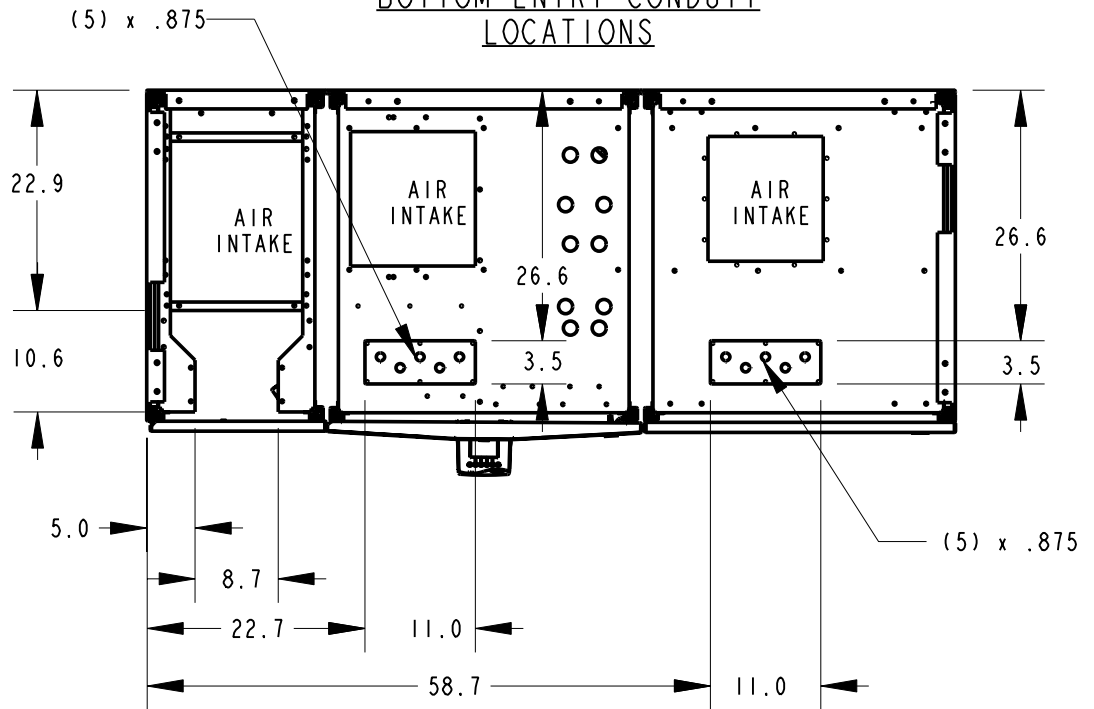

SEISMIC & INTERCONNECT BRACKET LOCATIONS

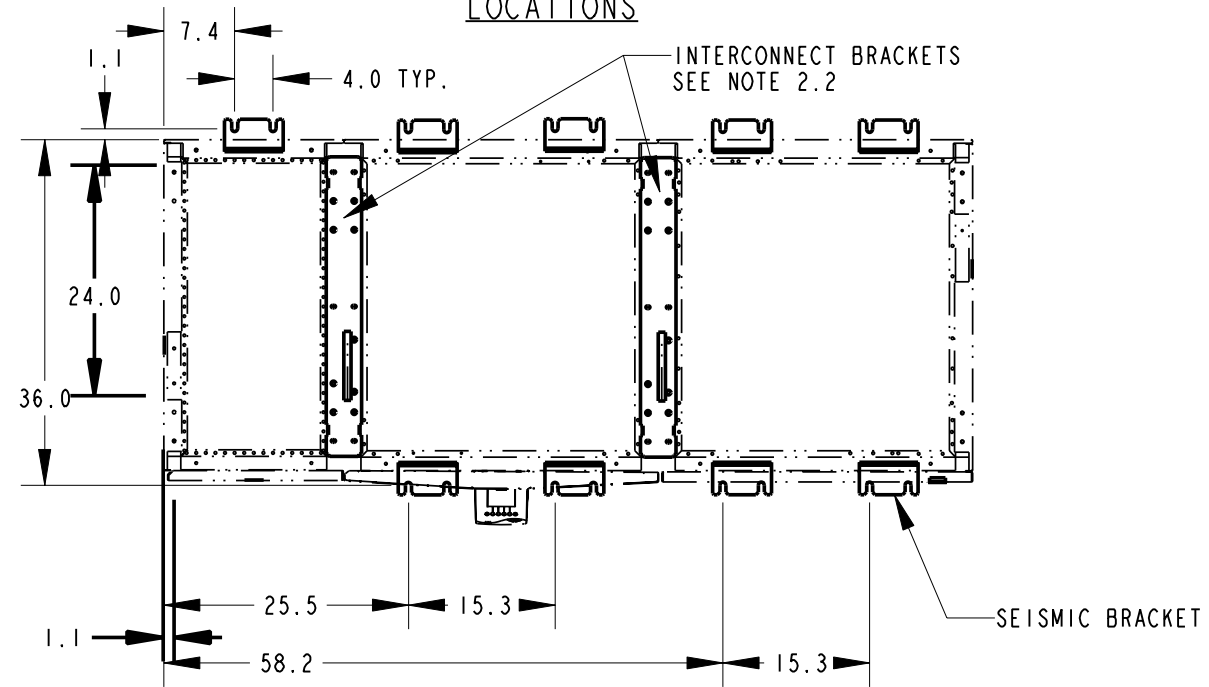

2.1. CONDUIT PLATE INSTALLATION INSTRUCTIONS:
 REMOVE SCREWS FROM CONDUIT PLATE. CONDUIT PLATE MAY NOW BE REMOVED TO PUNCH HOLES.
 REINSTALL CONDUIT PLATE AND SECURE WITH SCREWS.

2.2. INTERCONNECT BRACKETS INSTALLATION INSTRUCTIONS:
 ALIGN CABINETS NEXT TO EACH OTHER. REMOVE THE TOP PANELS, PLACE BRACKET OVER TOP
 TWO FRAME RAILS AND SECURE WITH SIX 10-32 SCREWS. PLACE TOP PANELS BACK AND SECURE
 WITH SUPPLIED HARDWARE.

NOTES: UNLESS OTHERWISE SPECIFIED.

SIZE B	FSCM NO. 9L985	DWG. NO. 90-170805-00	REV. B01
SCALE 0.050		90-17080X-XX.1	SHEET 2 OF 3

4 3 2 1

UPS SYSTEM WITH TRANSFORMER SINGLE LINE

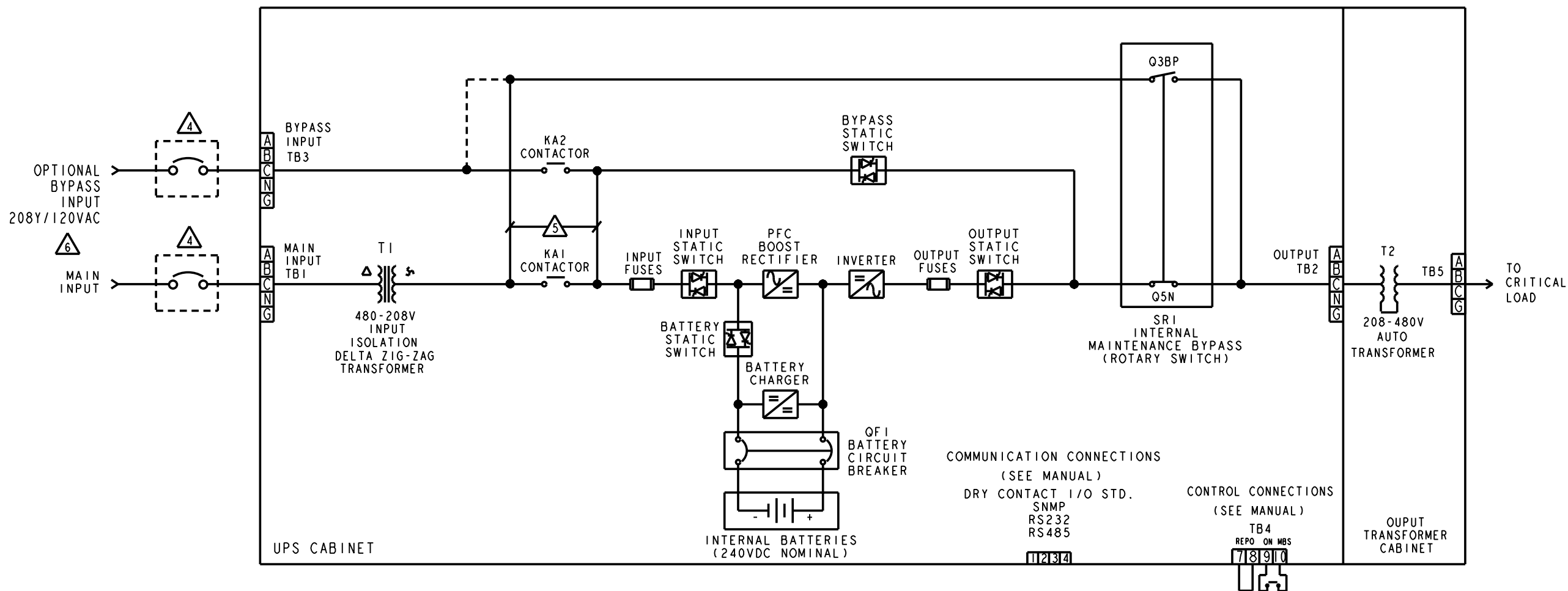

NOMINAL INPUT AND OUTPUT CURRENTS (A)

Vin/Vout	10KVA/8KW		15KVA/12KW		20KVA/16KW		30KVA/24KW	
	I (in)	I (out)	I (in)	I (out)	I (in)	I (out)	I (in)	I (out)
480/480	12	12	18	18	24	24	36	36

INPUT CIRCUIT BREAKER RATING

	10KVA/8KW	15KVA/12KW	20KVA/16KW	30KVA/24KW
480	20A	30A	40A	50A

MAXIMUM HEAT REJECTION (BTU'S)

10KVA/8KW	15KVA/12KW	20KVA/16KW	30KVA/24KW
4,100	6,100	8,200	12,200

ELECTRICAL SPECIFICATIONS

- FOLLOW ALL APPLICABLE NEC AND LOCAL ELECTRICAL CODES.
- ALL EXTERNAL WIRING BY OTHERS.
- POWER AND CONTROL CABLES SHALL BE IN SEPARATE CONDUITS.
- UPSTREAM PROTECTIVE DEVICE REQUIRED PROVIDED BY OTHERS.
- NOT PRESENT WITH SEPARATE BYPASS OPTION.
- INPUT/BYPASS SOURCE NEUTRAL SHALL BE SOLIDLY GROUNDED.

Frequency (in/out) 60Hz (+8% / -25%)
 Input Phase Rotation A,B,C, Clockwise
 Input PF > 0.98
 Input THD < 3%
 Input Voltage 480 (±15%) 3 Phase, 3W, N + G
 Nominal DC Voltage (Float) 240 VDC (272VDC) Float
 Min. DC Voltage 200 VDC
 Max. DC Current 60 ADC (10-15KVA), 120 ADC (20-30KVA)
 Internal Battery Disconnect (QF1) 63 A (10-15KVA), 125 A (20-30KVA)
 Internal Maintenance Bypass Switch (A) 55 A (10-15KVA), 100 A (20-30KVA)

NOTES: UNLESS OTHERWISE SPECIFIED.

SIZE B	FSCM NO. 9L985	DWG. NO. 90-170805-00	REV. B01
SCALE 0.031		90-17080X-XX.1	SHEET 3 OF 3